



Installer Handbook

Introduction

Established in 1997 and backed by a 25 year warranty, Ultima is a proven, reliable and cost effective end-to-end networking cabling solution

Reliable and Cost Effective

Manufactured and tested to the highest standards the Ultima range evolved in response to customer demand for a value engineered solution. Now used by 1000's of customers Ultima delivers the results every time. Product quality is guaranteed with our 25 year system warranty.



End-to-end Networking Solution

The range includes Cat5e, Cat6 and Cat6A Copper, Fibre Optic and Voice cabling solutions, Wall Boxes and a selection of Cable Management accessories.

Market Knowledge and Stability

Ultima products have been selected to give reliable and repeatable installed performance. Ultima employs staff with many years industry experience in manufacturing, sales and distribution and offer the highest levels of service and support.

Stock and Availability

Ultima products are centrally distributed from a 65,000 square foot, purpose built facility, providing significant warehouse capacity, ensuring Ultima products are available from stock for next day delivery.

Product quality is guaranteed

1.0 COPPER CABLING

1.1 Cable Types

Copper data cables are constructed from 4 pairs of wires that are twisted together in order to reduce the interference or crosstalk between the pairs. The 4 twisted pairs are then surrounded by a cable sheath that is typically a Low Smoke Zero Halogen (LSZH) or PVC material for internal cables or a Polyethylene (PE) material for external cables.

There are several different constructions of copper data cables, defined by the presence and nature of any overall and individual pair screening. There is a standardised method of defining the construction of a cable, as laid out in the international cabling standard ISO/IEC 11801. An unshielded cable is defined as U/UTP, where there is no overall shield or screen and no shield on the twisted pairs.



A cable that has an overall foil shield but no shields on the twisted pairs is defined as F/UTP.



Cables that have individually foil shielded pairs, but no overall foil, are defined as U/FTP and those with individually foil shielded pairs and an overall foil are defined as F/FTP. If an overall braided screen replaces the overall foil then the cable construction is defined as S/FTP, a design that is often referred to as PIMF (Pairs in Metal Foil).



Most Cat5e and Cat6 cables sold in the UK have a U/UTP construction but they may also be offered as F/UTP.

Cat6A cables are offered in many different variants, including U/UTP, F/UTP, U/FTP, F/FTP and S/FTP but, due to their extended bandwidth, Cat7 and Cat7A cables are generally only available in an S/FTP construction.

There are no specific rules about when to use an unshielded or shielded cable. Each installation should be considered on the basis of the amount of data to be transmitted, whether the cables will be loose laid or bundled, the proximity of the data cables to power cables or sources of electromagnetic interference (EMI), the type of containment in to which the cables will be installed and the budget that is available. It is important to remember that, when installing a shielded cabling solution, consideration should be given to the provision of a suitable earthing facility at each patch panel location.

1.2 Cabling Standards

The 4 main standards bodies relevant to the structured cabling industry are ANSI/TIA, ISO/IEC, CENELEC and BSI.

1.2.1 American National Standards Institute/ Telecommunications Industry Association (ANSI/TIA)

This body is responsible for the ANSI/TIA-568 series of standards:

- ANSI/TIA-568.0-D Generic Telecommunications Cabling for Customer Premises
- ANSI/TIA-568.1-D Commercial Building Telecommunications Cabling Standard
- ANSI/TIA-568-C.2 Balanced Twisted Pair Telecommunications Cabling and Components Standard
- ANSI/TIA-568.3-D Optical Fibre Cable Components Standards
- ANSI/TIA-568-C.4 Coaxial and Broadband Components



Note that, in the most recent revision (revision D), the revision designation letter is placed after the section numbers. This change in the standard naming convention will be applied to the other sections as and when they are revised.

1.2.2 International Standards Organisation/International Electrotechnical Commission (ISO/IEC)



ISO/IEC produces the ISO/IEC 11801 series of standards.

Edition 3 of ISO/IEC 11801 was published late 2017 and is broken down into different sections:

- ISO/IEC 11801-1 Generic Cabling Requirements
- ISO/IEC 11801-2 Commercial Premises
- ISO/IEC 11801-3 Industrial Premises
- ISO/IEC 11801-4 Homes
- ISO/IEC 11801-5 Data Centres
- ISO/IEC 11801-6 Smart Buildings

1.2.3 European Committee for Electrotechnical Standardisation (CENELEC)



CENELEC produce the EN50173 series of standards which are very similar to the ISO/IEC 11801 series.

EN50173	Information Technology – Generic Cabling Systems
EN 50173-1:2018	General Requirements
EN 50173-2:2018	Office Premises
EN 50173-3:2018	Industrial Premises
EN 50173-4:2018	Homes
EN 50173-5:2018	Data Centres
EN 50173-6:2018	Distributed Building Services

The EN50174 series of standards define the way in which cabling systems should be designed, installed and administered.

EN 50174-1:2018	Specification & Quality Assurance
EN 50174-2:2018	Installation planning & practices inside buildings
EN 50174-3:2013+A1:2017	Installation planning & practices outside buildings

Another relevant CENELEC standard is:

EN 50310:2016	Telecommunications bonding networks for buildings and other structures
---------------	--

1.2.4 British Standards Institute (BSI)



BSI currently adopts all CENELEC standards and prefixes them with the BS authority code, thus EN 50173:2011 becomes BS EN 50173:2011.

BSI is also responsible for producing their own UK specific standards, such as

BS 6701:2016+A1:2017	Telecommunications equipment and telecommunications cabling. Specification for installation, operation and maintenance
BS 8492:2016	Telecommunications equipment and telecommunications cabling - code of practice for fire performance and protection
BS 7671:2018	Requirements for Electrical Installations. IET Wiring Regulations (18th Edition)

BS 6701:2016, Clause 4.1.1 states that “All telecommunications cabling and telecommunications equipment shall meet all the requirements of the BS EN 50174 series of standards”. This has particular relevance to the installers of telecommunications cabling and telecommunications equipment as the word ‘shall’ makes compliance with this standard a contractual requirement.

When writing a cabling specification it is important to be clear which standard(s) are to be followed. In the UK adherence to the BS EN 50173 and BS EN 50174 series of standards, together with the relevant parts of BS 6701 and BS 7671 is recommended in order to ensure a fully compliant installation that conforms to UK legal requirements.

1.3 Category 8

The TIA published its Category 8 standard for components, permanent link and channel specifications late in 2016. Category 8 is backwards compatible to Cat6A, Cat6 and Cat5e and defines the use of twisted pair cabling to support up to 50GBase-T.

The ISO/IEC has defined new Classes of cabling specified for frequencies of up to 2GHz. Class I uses Cat 8.1 (RJ45) components, Class II cabling uses Cat 8.2 components (non-RJ45).

Both standards bodies are using the same assumptions, the use of 4-pair, balanced twisted pair copper cabling in a Channel using 2 connectors with a maximum cable run length of 30m (26m solid core conductor cables and 4m stranded conductor (patch) cable). This will make its use limited to data centre applications where cable run lengths are relatively short. It is highly unlikely that we will see Category 8 cabling being installed in general commercial environments. It is, however, the case that, due to Alien Crosstalk issues, any cabling specification, for the first time, only includes shielded cabling.

The TIA Category 8 and ISO/IEC Class I specifications both define the use of industry standard RJ45 connectors, enabling backwards compatibility and easy interfacing with existing active equipment. The ISO/IEC Class II specification supports the use of alternative connector interfaces that were previously developed for Category 7/7A such as the ARJ45 (Nexans GG45) and Siemon TERA connectors. The ARJ45 connector has an RJ45 footprint but the four pairs of contacts are positioned in the four corners of the aperture, rather than in a row across the top of the plug/socket.



Nexans GG45 Connector



Siemon TERA Connector

The RJ45 and GG45/TERA plugs are not interoperable, so adaptor cables are required to connect cabling systems with ARJ45/TERA connectivity to legacy equipment.

1.4 Definitions of Performance

ANSI/TIA, ISO/IEC and CENELEC (EN) use Category (often abbreviated to Cat) to define the performance of the cable and components used to make up a cabling system. However, it is only ANSI/TIA that uses Category to define the performance of the installed cabling system. ISO/IEC and CENELEC (EN) define the performance of the installed cabling through Classes.

The various Categories and Classes are as follows:

COMPONENT PERFORMANCE DESIGNATION		LINK/CHANNEL PERFORMANCE DESIGNATION		BANDWIDTH	APPLICATION
TIA	ISO/EN	TIA	ISO/EN		
			Class A	100 kHz	Voice
			Class B	1 MHz	ISDN
Category 3	Category 3	Category 3	Class C	16 MHz	10 Base-T
Category 4	Category 4	Category 4		20 MHz	16M Token Ring
Category 5	Category 5	Category 5		100 MHz	100 Base-T
Category 5e	Category 5e	Category 5e	Class D	100 MHz	1G Base-T
Category 6	Category 6	Category 6	Class E	250 MHz	1G Base-T
Category 6A	Category 6A	Category 6A	Class EA	500 MHz	10G Base-T
	Category 7		Class F	600 MHz	10G Base-T
	Category 7A		Class FA	1000 MHz	10G Base-T
Category 8	Category 8	Category 8	Class I/II	2000 MHz	40G Base-T

It is important to note that the performance of any particular Category of installed cabling is not the same as its associated Class. The ISO/EN standards tend to be more stringent, with tighter limits for the various specified parameters. This means that a cabling system that passes a specific Class will almost certainly pass the associated Category but a cabling installation that passes a specific Category will not necessarily pass the associated Class. For this reason, it is generally a good idea, unless specifically told to do otherwise, that installed cabling is tested to an ISO or EN standard rather than the TIA equivalent.

1.5 2.5 and 5 Gigabit Ethernet

The Institute of Electrical and Electronics Engineers (IEEE) develops the Ethernet applications that run over the installed cabling. Generally speaking, it is the development of a new application that drives the cabling standards bodies to develop cabling systems with the performance characteristics to support these new applications. However, this has not always been the case, with Cat 6/Class E cabling being a good example. In this instance the cabling standards bodies tried to pre-empt the development of 10GBase-T by the IEEE by launching Category 6/Class E cabling. When the 10GBase-T application was launched it was found that there were a number of issues with the Category 6/Class E cabling, principally to do with bandwidth and Alien (cable to cable) Crosstalk. As a result, Category 6A/Class EA cabling had to be developed.

With such a large global base of copper cabling installed the IEEE are looking at ways in which more data can be delivered down this existing infrastructure. One objective has been to find a way of making use of the additional bandwidth that Category 6/Class E cabling offers over Category 5e/Class D. The IEEE 802.11bz standard was published in late 2016 and defines transmission of 2.5GBase-T over Category 5e/Class D and 5GBase-T over Category 6/Class E. These represent a 250% and 500% increase in data transmission without any requirement to upgrade the cabling.

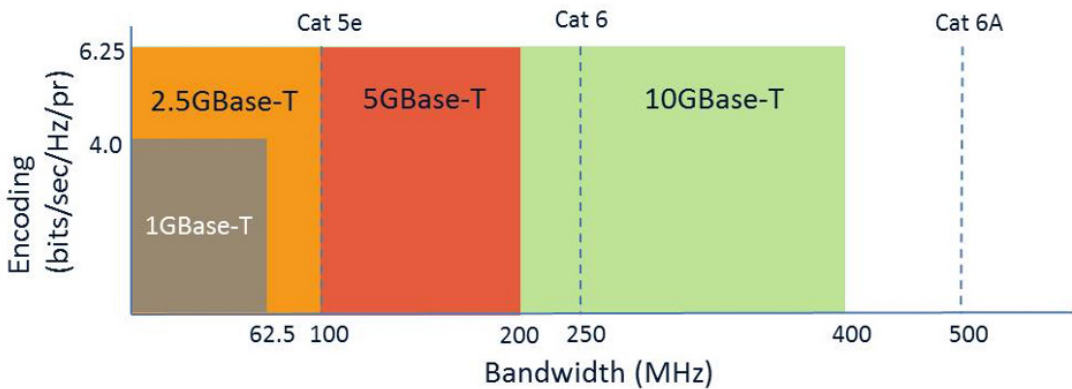

This has led the TIA to issue TIA TSB-5021 : 2017 Guidelines for the use of installed Category 5e and Category 6 cabling to support 2.5GBASE-T and 5GBASE-T. This Technical Service Bulletin reviews requirements for 2.5 and 5GBASE-T and any mitigation required when using existing Category 5e and 6 cabling. It has led to the development of the new parameter of ALSNR (Alien Limited Signal-to-Noise Ratio), which is essentially the ratio of alien crosstalk to insertion loss. This can be mitigated by reducing bundle sizes and cable run lengths and is not applicable to Cat 6A/Class EA. Therefore, it may not be as easy as simply plugging in new active equipment and expecting it to work. There may well be a requirement for additional testing and re-working of the installed cabling before these new applications can be supported.

The IEEE are also developing the 802.11bz standard for 25GBase-T and 50GBase-T, primarily for use in data centres. These new, high data transmission applications will require the development of new cabling solutions to support them.

(All standards information correct as of December 2019)

1.6 Construction Products Regulation (CPR) and EN50575:2014

The European Construction Products Regulations (CPR) was updated to include, for the first time, permanently installed cables. The CPR covers the testing and specification of all construction materials in terms of their fire performance, particularly with regard to the safety and ease of evacuation of people from buildings.

The CPR covers all permanently installed cables and includes data cables, power cables, BMS cables, coaxial cables and fibre optic cables. Generally speaking, cables that are fitted with a plug, such as patch leads and power cords, are not included in the scope of the CPR.

One of the problems with cabling is that there has been a proliferation of non-standardised and often proprietary terminology to define sheath materials and implied fire performance. These include:

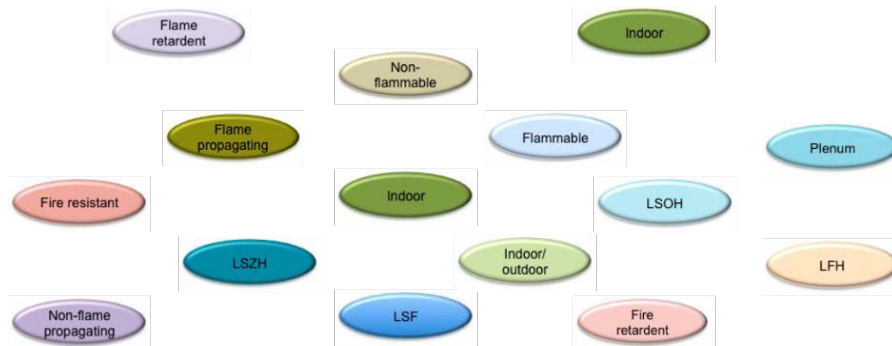

These random definitions are now obsolete as the CPR defines a framework of Euroclasses to categorise the different levels of fire performance of construction products.

EUROCLASS	
A	EuroClass A is for non-combustible products
B	EuroClass B1 is the best performance for flammable products
B2	EuroClass B2 products are capable of spreading fire to some degree
C	EuroClass C products are capable of spreading fire to a greater degree than B2 Products
D	EuroClass D products have burning characteristics similar to that of ordinary wood
E	EuroClass E products are difficult to ignite by a small flame but heat and smoke release is not assessed
F	EuroClass F is for products that fail to meet any of the above EuroClasses

EN 50575:2014 defines the testing regimes for cables in each Euroclass. It includes tests for flame propagation, smoke production, flaming droplet production and acid gas production. These test criteria are defined in the following table where the subscript 'ca' next to the Euroclasses shows that these test criteria refer to cables.

EUROCLASS	REACTION TO FIRE	SMOKE PRODUCTION	FLAMING DROPLETS	ACIDITY
Aca	Gross Heat of Combustion	Not Classified		
B1ca	Heat Release Flame Spread	s1a (Low Density) s1b s2 s3 (High Density)	d0 (Few) d1 d2 (Many)	a1 (Low) a2 a3 (High)
B2ca				
Cca				
Dca				
Eca	Flame Spread	Not Classified		
Fca	No Criteria			

Cables that have been tested will have a Declaration of Performance (DoP) available in the language of the country in to which they are to be sold and will have defined labelling attached to the packaging. Cables with a Euroclass of Aca and B1ca are unlikely to be available but that still leaves 106 possible combinations of B2, C and D Euroclasses with smoke production, flaming droplet and acidity parameters, plus Euroclass Eca!

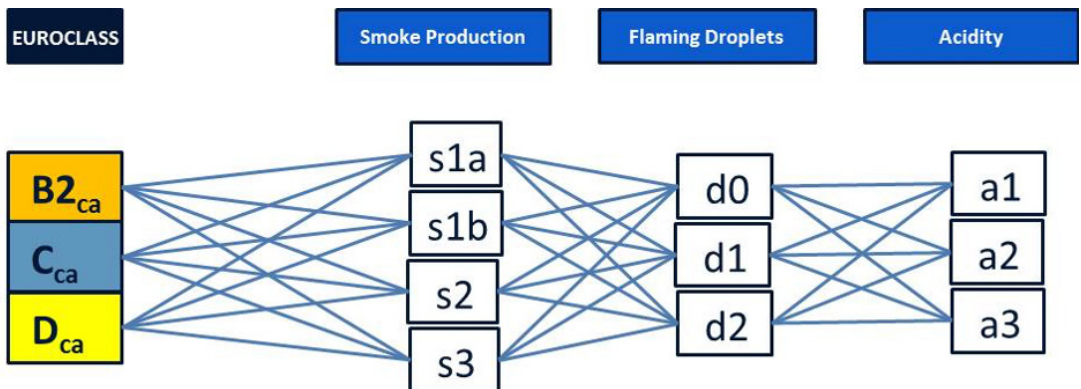

Obviously it will not be possible for cable manufacturers to produce 106 different variants of each cable so most will ultimately offer 'standard' and 'high' performing cables, i.e. Eca and Cca or B2ca. Most current PVC and LSZH sheathed U/UTP copper data cables achieve Euroclass Eca, with some shielded cables achieving Dca or better. New materials/constructions are required in order to achieve higher levels of performance but cables achieving Cca or B2ca compliance are already coming on to the market.

EN 50575:2014 came in to effect on 1st July 2017 and requires that all manufacturers and importers of cables for sale within the EU to have their cables tested and categorised to the new regulations by independent, accredited test laboratories. After that date it became against the law to sell non-conforming cables. Cables that were manufactured or imported prior to 1st July 2017 may still be sold and installed.

The Construction Products Regulations impose responsibilities and obligations on everyone in the supply chain. Specifiers will need to reference appropriate Euroclasses and s/d/a criteria according to national CPR regulations. Ongoing obligations (maintenance contracts, etc.) will need to be modified to reference Euroclasses. Installers will need to have an audit trail of materials purchased and installed for each project in order to be able to prove that what was specified was actually installed and end users/building owners will need to ensure that the infrastructure on plans is in line with national CPR regulations.

Cabling standards are currently being reviewed and updated to incorporate reference to the CPR legislation and will make recommendations on what Euroclasses of cables should be installed.

BS 6701:2016+A1:2017 incorporates a recommendation that any cables in new installations meet a minimum of Euroclass Cca-s1b,d2,a2.

BS 8492 will make recommendations in line with those in BS6701.

BS 7671 (18th Edition) make a recommendation for a minimum of Euroclass Eca.

BS 6701 is a standard that is, on occasion, listed in specification documents in addition to EN 50174 (Information technology - Cabling installation). It does not replace EN 50174.

BS 6701 is a standard and not a regulation, i.e. it is not enforceable in law. Standards simply provide guidance or recommendations where alternative solutions can be employed.

Therefore the use of Euroclass Cca cables will only become relevant where:

- a) It applies to any installations undertaken where BS 6701 or the specific clause (5.1.3.1) is referenced in the cabling specification, in which case failure to comply would put the installer in breach of contract;
- b) It only applies to "installation" cables as defined in BS 6701.

Ultimately it will be down to the specifier of the cabling system or the building owner to define what Euroclass of cable shall be installed but installers of cabling systems should ensure (and have documented evidence) that only cables with tested and certified Euroclass performance that meet the specification are installed. Otherwise they may find themselves culpable in the event of a fire related tragedy.

1.7 Wiring Schemes

There are two wiring schemes for terminating cables on to connecting hardware. These define the pin assignments for terminating the 8 wires of the 4 pairs in the data cable and are designated as 568A and 568B. The only difference between 568A and 568B is that pairs 2 and 3 (orange and green) are swapped

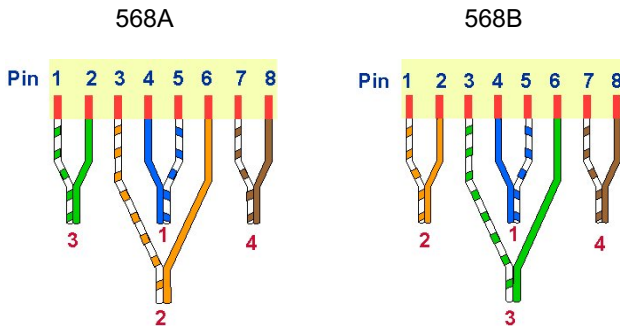

In the UK the preferred wiring scheme is 568B but there is no difference in the performance of 568A and 568B wiring configurations. It is, however, vitally important that the connectors at both ends of the cable use the same wiring scheme.

1.8 Cabling Topology and Terminology

The cabling standards define the basic configuration of a cabling scheme and terminology to describe the various elements.

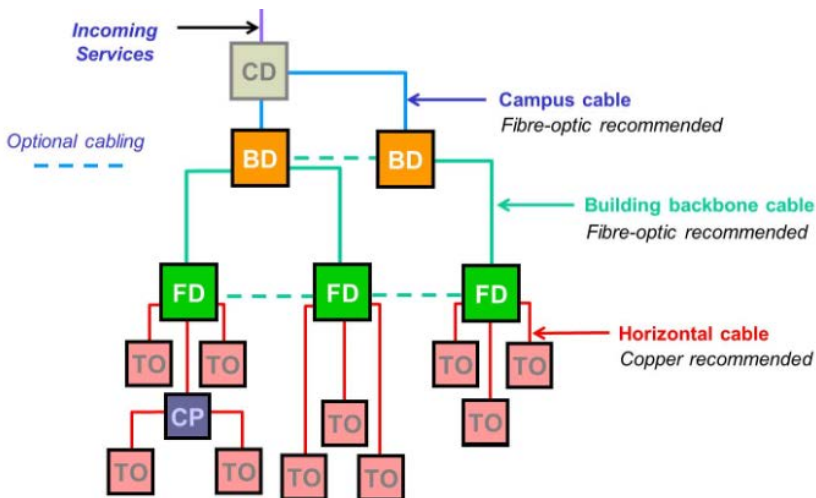

In the above diagram

CD = Campus Distributor BD = Building Distributor FD = Floor Distributor
 CP = Consolidation Point TO = Telecommunications Outlet

Any particular cabling system may contain all or just some of the above elements. For instance, in a small installation the Campus Distributor, Building Distributor and Floor Distributor may all be combined into a single cabinet, with no need for any fibre optic links. However, in a larger installation all of the above elements are likely to be present.

A schematic of a multi-building campus may look something like this:

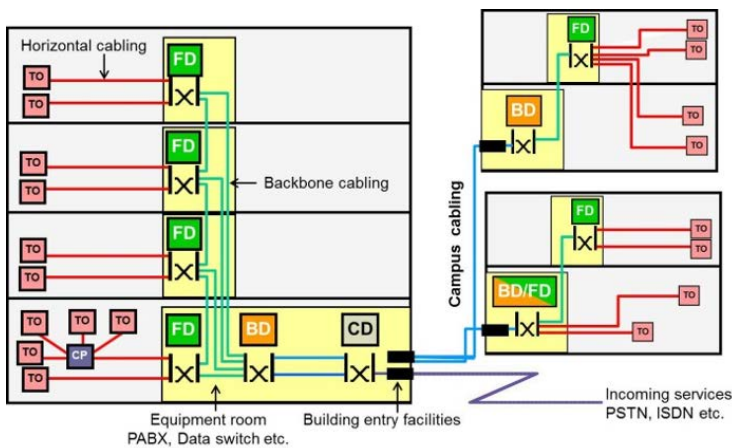

1.9 Patching Design Configurations

There are two basic cabling design configurations when it comes to connections between the horizontal cabling and the switches, inter-connect and cross-connect.

In an **inter-connect** configuration patching is done directly between the ports on the network switch and the ports on the horizontal patch panel.

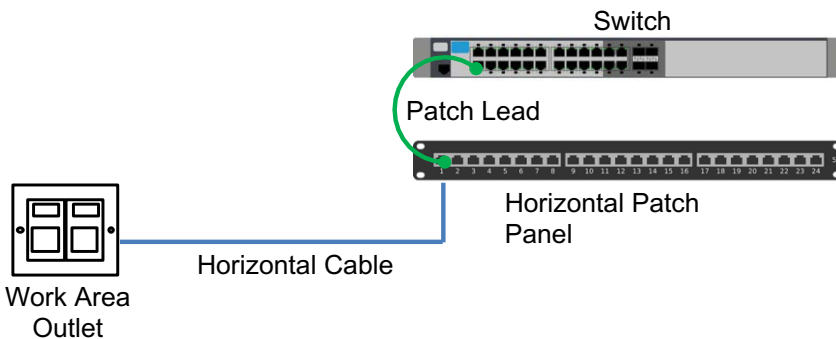

This design is the one most commonly used as it is quicker, easier and cheaper to deploy and requires less rack space. It is, however, less secure as patching technicians must have access to both the switches and horizontal patch panels.

In a **cross-connect** configuration the switch ports are connected to the rear of an equipment patch panel using a solid or stranded core switch link cable. This cable has an RJ45 plug on the switch end and is punched down onto the IDC contacts on the equipment patch panel. Patching is then carried out between the equipment patch panel and the horizontal patch panel.

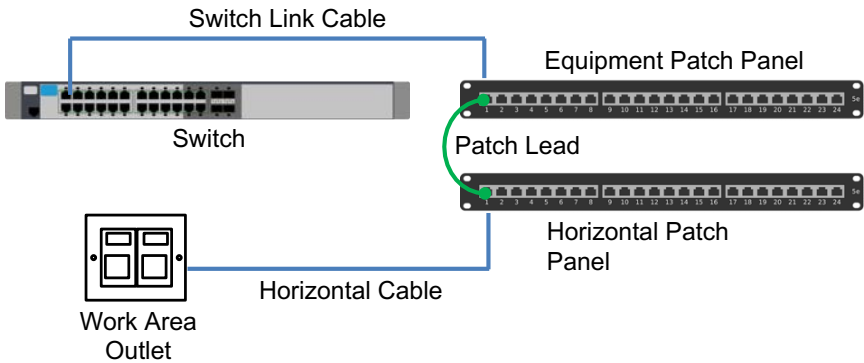

This configuration benefits from the fact that the expensive switches can be mounted in a separate, secure cabinet, away from the patch panels, thus preventing any tampering with the switches by the patching technicians. The downsides of this configuration are that it requires more rack space and more cabling components, with more labour required for their installation, all of which adds up to higher capital expenditure.

1.10 Structured Cabling Design Considerations

A copper cabling system is made up of a few basic components:

- Patch Panels
- Horizontal Cable
- Telecommunications or Work Area Outlets
- Patch Cords
- Consolidation Points (optional)
- Switch Link Cables (optional)

A basic structured cabling system will link the work area outlets (WAOs) to the patch panel(s) in the floor or building distributor via the horizontal cable. This design is referred to as a **Permanent Link** as, once installed, this cabling is fixed and unlikely to be changed.

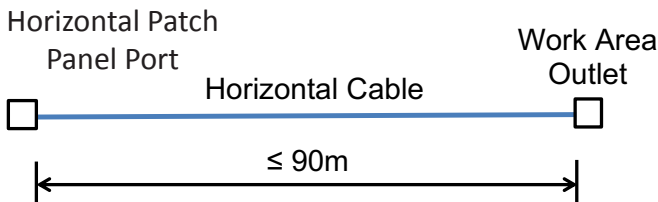

The maximum designed horizontal physical cable length of 90m is defined within the cabling standards in order to ensure that the cable attenuation is within the required limits.

When patch cords are connected to the patch panel port and to the work area outlet a basic **Channel** is created.

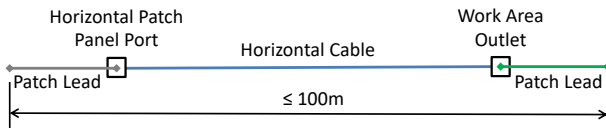

More complex Channels are created through the addition of a Consolidation Point and/or an Equipment Patch Panel with associated Switch Link Cables.

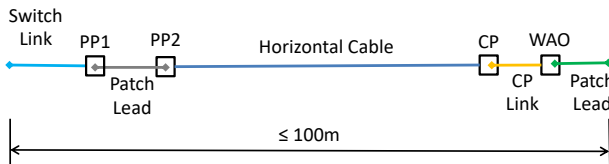

PP1 = Equipment or Cross-connect Patch Panel Port
 PP2 = Horizontal Patch Panel Port

The maximum length of the Channel is 100m, with a provision for 90m of solid core horizontal cable and 10m of stranded patch cord cable.

The Channel includes all of the elements of the cabling system over which the data is transmitted, including the patch cords, consolidation point links and cross connect patch panels. It is important to remember that the performance of the Channel is only as good as the performance of the lowest performing component within a Channel. For instance, if a Cat5e patch cord is connected to a permanent link made up of Cat6 components then the performance of the Channel can only be considered to be Cat5e.

The benefit of the Permanent Link is that it is easy to re-test at any point in the future because nothing should have changed since it was installed. This means that a direct comparison can be made between the performance of the cabling at that point in time and the performance at the time of original testing. On the other hand, in a Channel, each time a patch cord or consolidation point link is changed then the configuration and performance of the Channel is changed and it is not possible to directly compare the test results between the two different configurations.

1.11 Maximum Channel Lengths

The TIA 568-C standard defines the maximum length of the Permanent Link to be 90m and the maximum length of the Channel to be 100m, typically made up of 90m of solid conductor cable and 10m of stranded conductor cable.

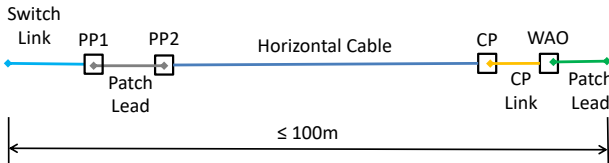

PP1 = Equipment or Cross-connect Patch Panel Port
 PP2 = Horizontal Patch Panel Port

The lengths specified in this standard refer to the physical sheath length, i.e. the actual measured distance between the distribution patch panel and the work area outlet when following the route of the cable. However, when testing the finished installation it is the electrical length of the cable that is measured. This will always be shorter than the physical length due to the twists in the wires. This means that there can be instances when testing links with a physical length of around 85m and longer where the electrical test can fail on length, even if the physical length of the cable is within the specifications.

Neither of the ISO/IEC 11801 or BS EN 50173 standards specify a maximum length of cabling. Instead the length is limited by the attenuation of the cable so, provided that good quality cable is used, it is extremely unlikely that any cabling with a physical length of less than 90m will fail to pass the relevant standard. Equally, when testing to these standards, it is possible that links with lengths in excess of 90m may still pass the electrical requirements.

Stranded cable is assumed to have an attenuation that is 50% higher than that of solid core cable. This means that, if extended length patch leads are used or if stranded cable is used in the Switch Links and/or the Consolidation Point links, the maximum length of the channel will be less than 100m. To calculate the maximum channel length for different cabling configurations refer to the following table and diagrams.

DIAGRAM	CABLING CONFIGURATION	MAXIMUM HORIZONTAL CABLE LENGTH CALCULATION		
		CLASS D	CLASS E	CLASS EA
1	Interconnect - TO	$H = 109 - (F \times X)$	$H = 107 - 3 - (F \times X)$	$H = 107 - 3 - (F \times X)$
2	Cross-connect - TO	$H = 107 - (F \times X)$	$H = 106 - 3 - (F \times X)$	$H = 107 - 3 - (F \times X)$
3	Interconnect - CP - TO	$H = 107 - (F \times X) - (C \times Y)$	$H = 106 - 3 - (F \times X) - (C \times Y)$	$H = 106 - 3 - (F \times X) - (C \times Y)$
4	Cross-connect - CP - TO	$H = 105 - (F \times X) - (C \times Y)$	$H = 105 - 3 - (F \times X) - (C \times Y)$	$H = 105 - 3 - (F \times X) - (C \times Y)$

Where:

H = Maximum length of solid core horizontal cable (m) F = Combined length of stranded patch cords

C = Length of CP Link cable X = Ratio of stranded cable insertion loss to solid cable insertion loss

Y = Ratio of CP Link cable insertion loss to solid cable insertion loss

Taken from EN 50173-2:2007+A1:2010, Clause 6.2.2.2. See standards document for details of adjustments to be made for ambient operating temperatures of higher than 20°C.

Diagram 1: Interconnect – TO

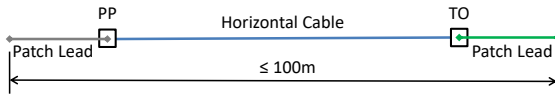

Diagram 2: Cross-connect – TO

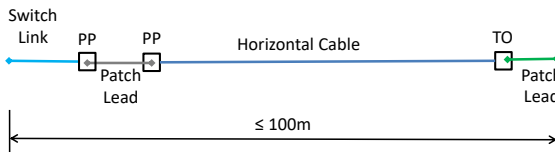

Diagram 3: Interconnect – CP – TO

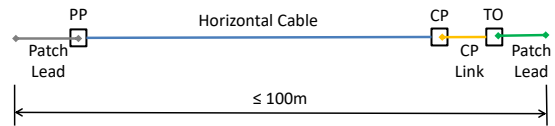
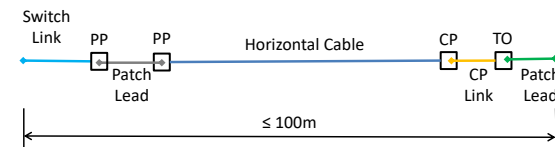

Diagram 4: Cross-connect – CP – TO



2.0 FIBRE OPTIC CABLING

2.1 Types of Optical Fibre

There are two basic types of optical fibre, multimode and singlemode.

In **multimode** fibres the light travels in multiple paths (modes) down the core of the fibre. The core of a multimode fibre has a graded index so that light passing down the centre of the core travels more slowly than light passing through the outer edges. This ensures that all of the different modes of light reach the far end of the cable at roughly the same time.

The core of a **singlemode** fibre is so small that the light travels in a single path (mode) down the core of the fibre.

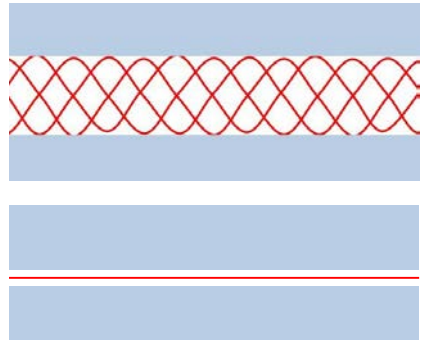

The relatively large core size of multimode fibres means that they can utilise relatively low cost light sources, such as Light Emitting Diodes (LEDs) or Vertical Cavity Surface Emitting Lasers (VCSELs). The very small core diameter of singlemode fibres means that high cost, very precise laser light sources must be used.

In voice and data networks there are generally two types of multimode fibre and one type of singlemode fibre. These are defined by the ratio between the core and cladding diameters, expressed in microns (thousandths of a millimetre).

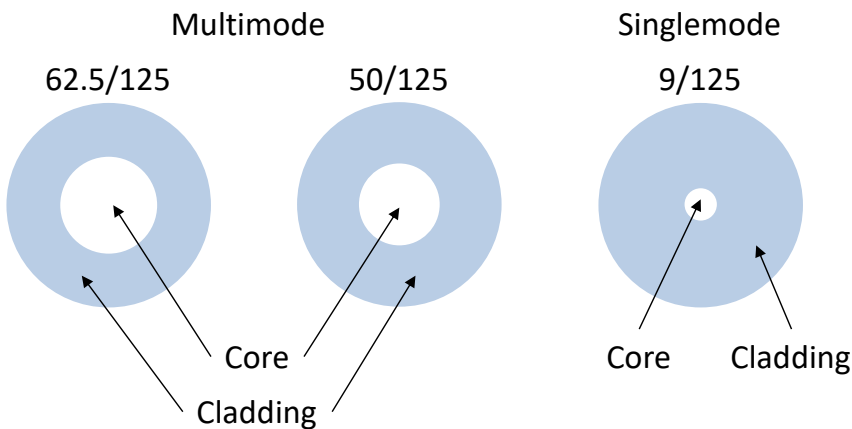

Prior to incorporation in to a fibre optic cable the fibres will have an additional 125µ thick coloured primary coating added, taking the overall diameter of the fibre up to 250µ. The primary coating provides protection to the fibre and enables identification of different fibres at each end of a cable.

2.2 Categories of Optical Fibre

There are five different grades of **multimode** optical fibres, as defined by their bandwidth, and are categorised as follows:

FIBRE CATEGORY	MINIMUM MODAL BANDWIDTH (MHZ.KM)				
	OVERFILLED LAUNCH BANDWIDTH			EFFECTIVE MODAL BANDWIDTH	
	850nm	953nm	1300nm	850nm	953nm
OM1	200	N/A	500	N/A	N/A
OM2	500	N/A	500	N/A	N/A
OM3	1500	N/A	500	2000	N/A
OM4	3500	N/A	500	4700	N/A
OM5	3500	1850	500	4700	2470

OM5 fibre is also referred to a Wideband Multimode Fibre (WBMMF). It uses multiple wavelengths to increase each fibre's capacity by at least a factor of four, which allows at least a fourfold data-rate increase (or a fourfold reduction in the number of fibres required to achieve a given data rate). The majority of modern cabling infrastructures will use OM3, OM4 or OM5 fibre, with OM1 and OM2 fibre generally only used in legacy installations.

Grades of **singlemode** optical fibres are defined by their attenuation, with OS2 fibre (also referred to as low water grade fibre) offering improved performance around the 1383nm wavelength.

FIBRE CATEGORY	MAXIMUM ATTENUATION		
	1310nm	1383nm	1510nm
OS1	1.0 dB/km		1.0 dB/km
OS2	0.4 dB/km	0.4 dB/km	0.4 dB/km

2.3 Optical Fibre Application Support

Unlike with copper, where a higher category of performance offers support of higher data transmission rates, an improvement in the grade of fibre offers increased transmission distance for the applications designed to run over it.

This is summarised in the table below.

APPLICATION	IEEE 802.3 LINK DISTANCE						
	OM1	OM2	OM3	OM4	OM5	OS1	OS2
1000Base-SR	275m	550m				2km	5km
1000Base-LX						2km	5km
10GBase-SR	33m	82m	300m	400m	400m		
10GBase-LR						2km	10km
10GBase-ER						2km	22km
40GBase-SR4			100m	150m	150m		
50GBase-SR			70m	100m	100m		
100GBase-SR10			100m	150m	150m		
100GBase-SR4			70m	100m	100m		
200GBase-SR4			70m	100m	100m		
400GBase-SR16			70m	100m	100m		
100GBase-LR4						10km	10km
100gBase-ER4						40km	40km

Taking the example of 10GBase-SR above we can see that the supported distance for this application over OM1 and OM2 fibre is less than can be achieved for the same data rate (10 Gigabits/sec) over Category 6A copper cable, which would be more cost effective to install.

2.4 Selecting the Right Optical Fibre Type

The choice of which type of fibre optic cable to install will depend on a number of different factors, including:

- Application(s) to be supported
- Distance over which applications must be supported
- Anticipated lifespan of the infrastructure
- Budget available

Singlemode fibre optic cables are generally much cheaper than their multimode equivalents as significantly more singlemode fibre is produced than multimode because it is used in long haul telecommunications networks. The flip side of this is that the light sources required to utilise singlemode fibre are much more expensive than those used with multimode fibre. Additionally, the connectors used on singlemode fibre are more expensive as they have to be manufactured to much tighter tolerances.

As a general rule of thumb, multimode fibres are used within buildings and for connections between buildings that are relatively close together, whereas singlemode fibres are used externally for linking buildings on large campuses or sites spread over a large geographical area. There is, however, a growing use of singlemode fibre inside buildings, particularly in data centres, where there is a requirement to support very high data rates, even over relatively short distances.

2.5 Fibre Optic Cable Types

Fibre optic cables can be split into two key types, Loose Tube and Tight Buffered.

2.5.1 Loose Tube Cables

In a loose tube fibre optic cable a number of 250µ primary coated fibres are contained within a plastic tube which may or may not contain a water blocking gel. This type of fibre optic cable has traditionally been used in telecommunications networks where they are predominantly installed in external environments.

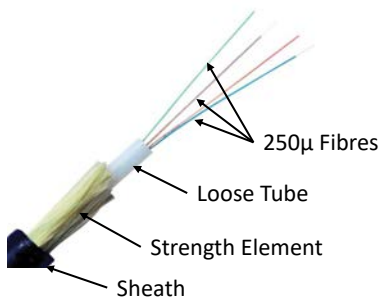

The loose tube will generally contain between 2 and 24 fibres and multiple loose tubes can be incorporated into a single cable so that cables containing many hundreds of fibres can be produced.

2.5.2 Tight Buffered Cables

A problem with loose tube cables is that they are not suitable for use in vertical cable runs. This is because the 250µ fibres have very little strength and the fact that they are not supported within the loose tube means that they are liable to break unless a loop is created in the fibre optic cable every 10-15m. There is also the risk that any water blocking gel from inside the loose tube will run out at the lowest point where the cable is terminated.

These issues led to the development of tight buffered cables where the 250µ primary coated fibres have an additional secondary coating (buffer) which has an overall diameter of 900µ (0.9mm). These 900µ buffered fibres are sufficiently strong that they do not need to be contained within a loose tube and they are suitable for use in vertical cable runs.

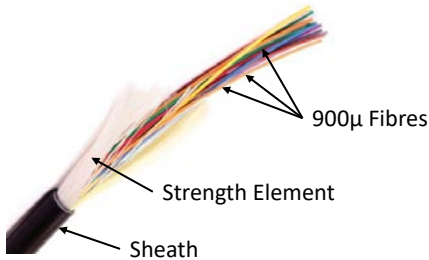

Tight buffered cables tend to have a maximum of 24 fibres and are suitable for both horizontal and vertical cable runs.

Both loose tube cables and tight buffered cables may be supplied with either a Low Smoke, Zero Halogen (LSZH) sheath or a Polyethylene (PE) sheath. Cables with a LSZH sheath can generally be used internally and externally when installed in a dry duct. PE sheathed cables may only be used in external cable runs but are not susceptible to water ingress.

The strength elements may be Aramid Yarn or E-glass yarn, the latter of which adds a degree of rodent resistance.

2.6 Fibre Optic Connectors

There are several different styles of fibre optic connector that are currently used in data networks.

ST Connector



The ST connector has a round barrel and a 2.5mm diameter ferrule. It uses a bayonet fixing mechanism to secure it to the adaptor and is not recommended for new installations.

SC Connector

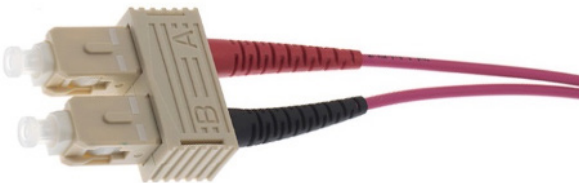

The SC connector has a square format and a 2.5mm diameter ferrule. It has a push/pull latching mechanism, making it easy to use. Two SC connectors are generally linked using a special clip to create a SC Duplex connector.

LC Connector



Thanks to a 1.25mm diameter ferrule the LC connector is significantly smaller than its ST and SC counterparts. Sometimes referred to as a Small Form Factor (SFF) connector it is possible to get twice as many fibres terminated on LC connectors in the space used by SC connectors. LC connectors have a simple latch, similar to that used on a RJ45 plug, making it familiar in use for network technicians. This has become the connector of choice in most new network fibre installations.

MPO or MTP® Connector



The MPO or MTP® connector has similar dimensions to the LC Duplex connector but can accommodate up to 32 fibres in a single, rectangular ferrule. This makes it ideal for multi-channel fibre applications such as 40G and 100G Ethernet. The need to precisely align the fibre end faces means that both male (with alignment pins) and female (without alignment pins) connector types are required. This connector type is not suitable for field termination.

2.7 Fibre Optic Adaptors

Fibre optic adaptors are used to join fibre connectors together. They contain a precision alignment sleeve that securely holds the ferrule of the connectors so that the fibre end faces are precisely aligned and are as close together as possible. The adaptors may have the same connector type on both sides or may have different connector types, enabling fibres that have been terminated on different types of connectors to be joined. Fibre adaptors are typically mounted in patch panels, breakout boxes or work area outlets.

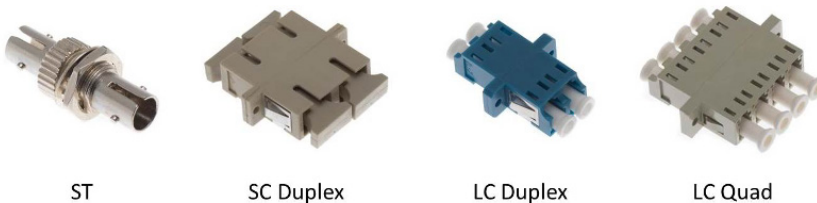

An LC Quad adaptor has the same mounting dimensions as an SC Duplex adaptor which means that it is possible to get twice as many terminations in the same amount of space.

2.8 Fibre Optic Ferrules

When joining two optical fibres using connectors inserted in to an adaptor it is important to minimise the air gap between the end faces of the two ferrules as any gap will lead to Optical Return Loss (ORL) which is the reflection of light back down the fibre.

The original Flat Ferrule connectors had a relatively large end face surface area that enabled a large number of small but significant contaminants and imperfections to be present. These lead to an increasing of the air gap and a reduction in performance. This led to the development of Physical Contact (PC) connectors, where the outer corners of the ferrule are chamfered in order to reduce the surface area of the ferrule end face.

Using an extended polishing method creates an even smaller ferrule end face, referred to as the Ultra Physical Contact (UPC) connector. This results in a lower ORL than a standard PC connector, allowing more reliable data transmission. UPC connectors are now the most commonly used type.

Some applications require very low optical return losses, in the region of one-in-a-million (60dB). This can be achieved through the use of Angled Physical Contact (APC) connectors that have an 8° angle to the ferrule end-face which creates a smaller end-face area and reduced Fresnel losses.

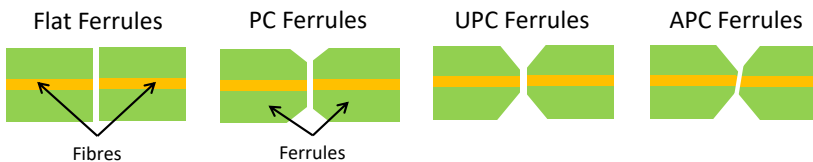

For illustration purposes only. Not to scale. Colours added for clarity.

2.9 Fibre Optic Connector Termination Methods

There are a number of different ways in which optical fibres can be secured to fibre optic connectors.

2.9.1 Epoxy & Polish Connectors

The traditional way to terminate a fibre in a connector has been to apply some form of glue or epoxy to the prepared fibre before it is inserted into the ferrule of the connector. The epoxy then cures (hardens), thus firmly attaching the fibre to the inside of the ferrule. Any excess fibre length must then be cleaved before the fibre end and ferrule are carefully polished to achieve a flat, smooth finish. The level of skill required, the time taken to complete a termination and the low level of losses that are required in modern networks have all contributed to a decline in the use of this type of termination technique.

2.9.2 Pre-Polished Connectors

These connectors have a short stub of fibre installed in the ferrule by the manufacturer of the connector. The ferrule end face is polished by the manufacturer, removing the need to carry out this operation on-site. When the prepared fibre is inserted into the rear of the connector an index matching gel is used to bridge the gap between the two fibres. The inserted fibre is held in place using some form of clamp or locking mechanism on the rear of the connector. This type of connector is relatively easy to use but they are expensive when compared to epoxy style connectors.

2.9.3 Pigtails

A pigtail is a short length (typically 1 metre) of 900µ buffered fibre that has been factory terminated with a fibre optic connector, thus eliminating the need for any on-site termination or polishing of the connector. The pigtail is attached to the cable fibre by splicing the end of the fibre of the pigtail to the end of the fibre of the cable. The preferred method of splicing is Fusion Splicing, where the two fibres are melted together using a high powered electric arc to effectively create one, single, continuous strand of glass. The joint between the two fibres is then protected using a splice protection sleeve that usually comprises a heat shrink polymer tube with an embedded stainless steel rod.



Precision Cleaver



Fusion Splicer

Fusion splicing requires the use of precision fibre cleaving tools and a fusion splicing machine. Modern fusion splice machines automatically align the two fibre end faces and fuse the two together to create a very low loss joint. The fusion splicing machines often also have an integral oven that is used to heat shrink the splice protector around the fibre joint.

2.9.4 Pre-Terminated Cable Assemblies

A Pre-terminated fibre optic cable assemblies are becoming a popular choice where the time available on site is limited or where there is a lack of suitably skilled operators. The cable assemblies can be produced to precise customer specifications, with options for length, cable type, fibre type, breakout type and connector type. Pre-terminated cable assemblies provide a 'plug-and-play' solution that frees up labour for other tasks.

An increasingly popular method for pre-terminated assemblies is MPO or MTP® multi-fibre connectors as these provide the ultimate in ease of installation for multi-fibre, high density installations. These connectors are always factory terminated due to the precision polishing that is required.

Pre-terminated assemblies require accurate surveys of the cable routes, advanced planning and allowance for the factory termination and delivery times.

3.0 CABLE INSTALLATION

3.1 Cable Installation Practices

The design and installation of structured cabling systems in the UK should be compliant with the latest published editions of BS EN 50173, BS EN 50174, BS 6701 and BS 7671. The Quality Assurance provisions applied to the installation should be compliant with the published edition of BS EN 50174 which is current at the date of installation. It is the responsibility of the contractor to ensure that they are fully aware of the content of these standards and how they apply to any particular installation carried out by them. It is important to be aware that certain aspects of the specifications are legally binding. In particular, BS6701:2010 states that 'All telecommunications cabling and telecommunications equipment shall meet all of the requirements of the BS EN 50174 series of standards'. This relates to both owners of premises (Clause 4) and installers of telecommunications cabling and telecommunications equipment (Clause 5).

The following are some basic practices that should be observed as part of any structured cabling installation.

3.1.1 Pathways

Always try to install cabling along routes that provide easy access to the cabling at any point in the future. These include corridors and walkways, where there would be the minimum of disruption to the business operations. Voids above suspended ceilings and sub-floor spaces provide good cable routes as the installed cabling is hidden from view but access is still relatively easy. Where it is not possible to use these routes surface mounted trunking is a viable solution but be aware of the limited cable capacity.

Areas where there is a high potential risk of electromagnetic interference (EMI) should be avoided. Separation distances between data cables and specific EMI sources are as follows:

SOURCE OF EMI	MINIMUM SEPARATION
Fluorescent Lamps	130mm
Neon Lamps	130mm
Mercury Vapour Lamps	130mm
High-intensity Discharge Lamps	130mm
Arc Welders	800mm
Frequency Induction Heating	1000mm

Wherever possible use containment that has rounded corners as this will help to maintain cable bend radii and avoid long term damage to cables. Any sharp edges or corners should be protected and cabling should never be laid directly on a suspended ceiling tile grid.

3.1.2 Containment

Avoid mixing different cable types in the same containment where possible and remember that power and data cables should never share the same compartment in any piece of containment.

Unacceptable

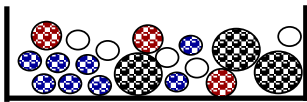

Good Practice

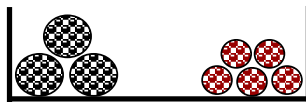

Power cables



Data cables



Sensitive circuits



Auxiliary circuits

Recommended

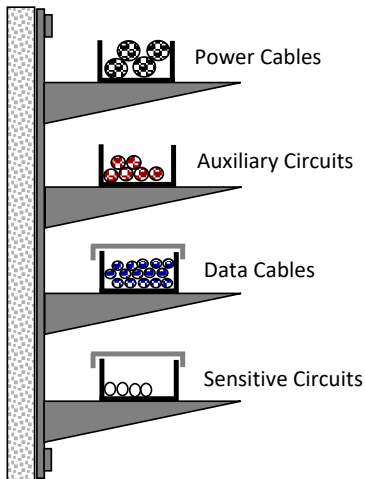

Power and data separation distances depend on the type of cable and the nature of the containment:

CABLE TYPE	CABLE MANAGEMENT SYSTEM			
	NON-METALLIC	OPEN METALLIC	PERFORATED METALLIC	SOLID METALLIC
Coaxial	300mm	225mm	150mm	0mm
Cat 5e, 6 or 6A U/UTP	100mm	75mm	50mm	0mm
Cat 5e, 6 or 6A F/UTP	50mm	38mm	25mm	0mm
Cat 7 or 7A S/FTP	10mm	8mm	5mm	0mm

Any containment should be large enough for the number of cables to be accommodated; remembering that a calculated 60% fill will actually completely fill the containment due to air gaps. To allow an extra 50% space for future expansion, moves, adds and changes the containment should only have a 40% fill at the time of initial installation.



40% Fill



60% Fill

All containment should be vertical or horizontal, never diagonal and remember that bends and junctions reduce the amount of available space.

3.1.3 Cable Installation

When pulling in copper twisted pair cables a maximum pulling force of 110N (11kg) per cable should not be exceeded. Ensure that cables run freely out of boxes or off reels and that they are fed around tight corners. Installed cabling should be generally free of tension, with only the self-weight of individual cables being carried.

Avoid pulling in cables in cold conditions ($<0^{\circ}\text{C}$) as the copper wires become brittle below this temperature and may snap if bent or stressed. Cables that have been stored in low temperature conditions should be allowed to warm up before attempting to pull them in. Avoid installing cables in areas of high temperature as attenuation increases as the temperature rises.

Ensure that minimum cable bend radii are maintained. The minimum cable bend radius should be greater than 8 times the cable outside diameter (OD) during installation and greater than 4 times the cable OD after installation.

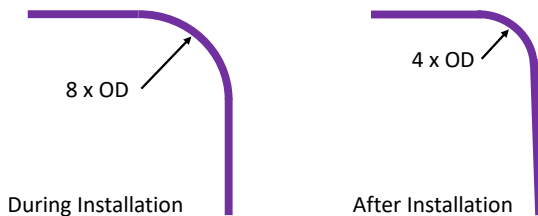

As a general rule of thumb cables should not be bent any tighter than they would be if wrapped around the outside of a coffee mug.

Cables in horizontal containment should be loose laid in order to minimise the risk of Alien Crosstalk (cable to cable interference) and heat build-up in PoE systems. Where cables are loose laid in cable tray or basket they should be secured with a cable tie around the outside of the tray or basket at 1m intervals to prevent cables from falling out of the containment. If, despite acknowledging the above, the client insists on bundling of the cables, then the cables should be formed into bundles of no more than 24 cables using loose fitting cable ties or hook & loop (e.g. Velcro®) straps spaced at 500mm intervals. Cables should be secured at any change in direction, either horizontally or at a horizontal to vertical transition.



Within cabinets the cable bundle size should not exceed 24 cables. Vertical cabling should be formed into bundles of no more than 24 cables and should be supported at 500mm centres or less where accessible. Wherever possible measures should be taken to avoid securing cable bundles to each other.

Where cabling is suspended horizontally, supports should be provided at no more than 1200mm centres.

3.1.4 Earthing, Grounding & Bonding

This should be left to a qualified and competent electrical contractor. All earthing, grounding and bonding should be carried out in accordance with EN50174-2 and EN50310.

For shielded cabling systems the use of full height earthing bus bars in cabinets and racks is recommended. Earth wires linking patch panels to the bus bars should be as short as possible and stranded or braided earth straps are better than solid conductor earth wires as they have a larger overall surface area and provide a lower impedance path to earth for unwanted signals. Shielded cabling solutions should always be earthed at the patch panel end only. Earthing at both the patch panel and work area outlet can cause ground earth loops to be created. Earths on shielded patch panels should never be 'daisy chained' together; each patch panel should have its own, discreet connection to the earthing bus bar.

3.2 Copper Cable Termination

Always follow the manufacturer's recommended termination practices. An instruction sheet should be included with the products and/or be available for download from the manufacturer's website.

The cable sheath should be cut using a special tool such as a 'Cyclops' cutter to avoid potential damage to the cable shields or wire insulation. Only remove sufficient sheath to enable termination as the sheath maintains the configuration of the pairs within the cable. For cables that utilise a central pair separator such as an extruded plastic cross this should be cut back as close as possible to the point from which it leaves the cable sheath. The cable sheath should be maintained as close as possible to the point of termination.

Wires should be dressed in to the appropriately coloured termination slot, taking care to ensure that the same wiring configuration (568A or 568B) is used at both ends of the cable. Pair twists should be maintained as close as possible to the point of termination, with a maximum of 12mm of pair untwist for Cat5e and a maximum of 6mm of pair untwist for Cat6.

Only use the tools specified by the manufacturer of the cabling system for the termination of the wires. Never use an unsuitable tool (screwdriver, knife blade, etc.) to terminate cables in to Insulation Displacement Contact (IDC) blocks. Replace tools/blades regularly in order to ensure better quality and faster terminations.

When terminating shielded cables the cable shield should always be terminated on the patch panel and work area outlet. Always use the foil or braid to provide the primary shield termination as these present a larger surface area and a subsequent lower impedance path to earth than simply using the drain wire. When terminating cables with foil screened pairs, e.g. U/FTP, the foils should be maintained as close as possible to the point of termination in order to minimise the risk of Near End Crosstalk (NEXT).

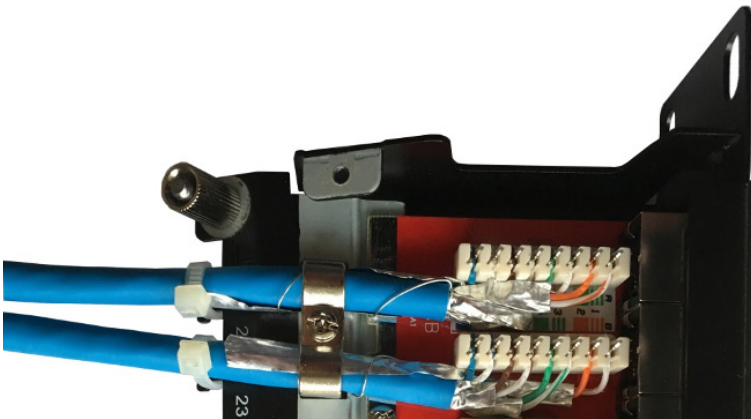

Always use the cable strain relief facility provided by the manufacturer but avoid overtightening of cable ties.

3.3 Labelling

All elements of the structured cabling system should be labelled in accordance with ISO/IEC 14763-1.

Items to be labelled include:

- Patch panel ports
- Horizontal cables (at both ends)
- Backbone cables (at both ends)
- Outlets
- Cabinets
- Earthing Points

The labelling scheme should be agreed with the client prior to commencement of installation of the cabling and should be consistent throughout the installation. The labelling scheme does not need to be complex as it is primarily there in order to be able to identify both ends of the link. For more complex installations where there are multiple distribution cabinets or diverse routing of cables a more detailed labelling scheme might be required.

Examples of labelling schemes are as follows:

Patch Panel Ports, Work Area Outlets and Horizontal Cables

Typical configuration = F/C/P/N, where:

F = Floor Number

C = Cabinet Reference

P = Panel

N = Port Number of Panel

e.g. G/A/1/24 = Ground Floor, Cabinet A, Panel 1, Port 24

Backbone cabling

Typical configuration = B/F/C/P/N, where:

B = Building

F = Floor Number

C = Cabinet Reference

P = Panel

N = Port Number of Panel

e.g. A/G/C/2/4 - C/1/D/1/4 = Building A, Ground Floor, Cabinet C, Panel 2, Port 4 to
Building C, First Floor, Cabinet D, Panel 1, Port 4

All labelling must be permanent, legible and UV stable and completed prior to testing. Under no circumstances should the labels be hand written or permanent markers be used to identify the components or cables. Labels on cables should be of the self-laminating wrap around type and the label reference should be identical at both ends of the cable.

Labels used on consolidation points, patch panels and outlets and for cabinets and earthing points should ideally be of the engraved type. Labels should be applied to the front and rear of each cabinet and frame. The patch panel numbering sequence should start at the top left of the cabinet or frame and work across and down.

4.0 COPPER CABLE TESTING

4.1 Copper Cable Test Equipment

It is essential that all cabling is tested on completion of the installation using a suitable cabling certification tester, i.e. a tester that can perform all of the test procedures required within the cabling standards. Cabling verification testers, i.e. those that perform only a limited range of tests, such as wiremap and length measurement, are not suitable for certifying the performance of newly installed cabling. The standard(s) to which the installed cabling should be tested will be defined within the project specification document or by the manufacturer of the cabling system.

Make sure that the test equipment is suitable for the testing to be carried out. Test equipment performance is defined by levels:

- Level IIe test equipment or better is required to test Class D/Cat5e cabling (100 MHz)
- Level III test equipment or better is required to test Class E/Cat6 cabling (250 MHz)
- Level IIIe test equipment or better is required to test Class EA/Cat6A cabling (500 MHz)
- Level IV test equipment or better is required to test Class F/Cat7 cabling (600 MHz)
- Level V test equipment or better is required to test Class FA/Cat7A cabling (1000 MHz)
- Level 2G test equipment or better is required to test Class II/Cat8 cabling (2000 MHz)



Prior to commencement of testing it is vital to ensure that the tester calibration certificate is valid. The timescales for re-calibration of the tester will be specified by the tester manufacturer but it is typically every 12 months. If the calibration certificate is not valid then the test results will almost certainly not be accepted by the cabling system manufacturer under any extended warranty programme.

The tester should then be set up for the standard to which the cabling will be tested, the type of cable to be tested and the cable's Nominal Velocity of Propagation (NVP). The NVP is the speed that the electrical signal travels down the cable relative to the speed of light and is usually expressed as a percentage. If the speed of the signal and the time taken for it to travel down the cable are known then the length of the cable can be calculated. If an incorrect NVP is set then all of the cable length measurements will be incorrect.

The condition of the permanent link adaptors/test heads should be checked and replaced if necessary. Poor quality test leads/heads will lead to poor/incorrect test results.

It is recommended practice to test the performance of the permanent link, i.e. the fixed portion of the cabling between the patch panel and the consolidation point (CP) or work area outlet (WAO). Testing of the Channel is not recommended as its performance will change each time the patch cords are changed.

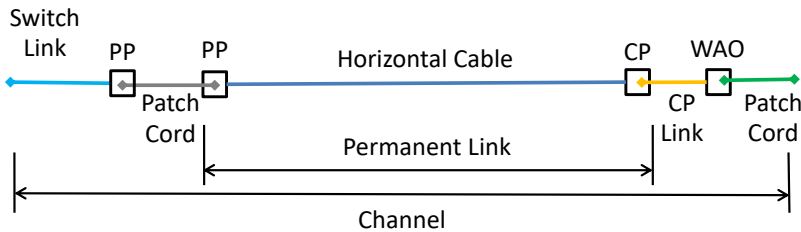

It should be noted that, when testing the Permanent Link, the plugs on the tester permanent link adaptors/ test leads that are connected to the patch panel and consolidation point/work area outlet are included in the test regime. This is because the test configuration includes the plug and socket interface at each end of the link as it is not possible to test a link without inserting a test plug at each end! This is an important consideration as these plugs will have an influence on the measured performance of the Permanent Link. If consistently poor performance results are experienced then the first thing to check is the quality/age of these plugs.

The Channel does not include the plugs at each end and they are referenced out by the test equipment. It is important to remember that the plugs on each end of a patch cord will not necessarily have the same performance and that, when testing a 'failing' Channel, it is always worth reversing the patch leads at each end to ensure that these are not the cause of any performance problems.

For a good quality cabling installation using good quality cable and components only 'PASS' test results with a good margin of performance should be seen. *PASS and *FAIL results are those where the margin of performance of the cabling system is within the test equipment's limits of accuracy and remedial action should be taken to improve the performance in order to achieve a full PASS result. As a general rule of thumb, poor/FAIL results can be categorised as follows:

- NEXT - usually down to poor quality terminations such as cable pairs untwisted too much
- Return Loss (RL) - usually down to cable issues such as too many/too tight bends, excess pulling force or over-tight cable ties

Where available use the test equipment's diagnostic tools to help locate the causes of issues.

*PASS, *FAIL and FAIL test results will not generally be accepted by the manufacturer of the cabling system for warranty application purposes.

For ease of identification the test results should be saved using the outlet labelling convention. Full test results, including graphs, should be saved in the test equipment's native format and should be downloaded from the tester on a regular basis in order to minimise the risk of lost test results. A summary test report, together with an electronic copy of the full test results should be passed to the client as part of the O&M manual, with copies kept by the cabling installer for future reference.

5.0 FIBRE OPTIC CABLE TESTING

5.1 Fibre End Face Inspection

Dirty or damaged fibre optic connectors are the responsible for 85% of network problems and are the number one cause of network failures. Even brand new patch leads, fresh out of the bag, can be contaminated through dust cap degradation. If the end faces are not inspected prior to testing it is not possible to know how clean they are so always “Inspect Before You Connect”. Remember that a dirty end face on a test lead will contaminate every port that it is plugged in to.

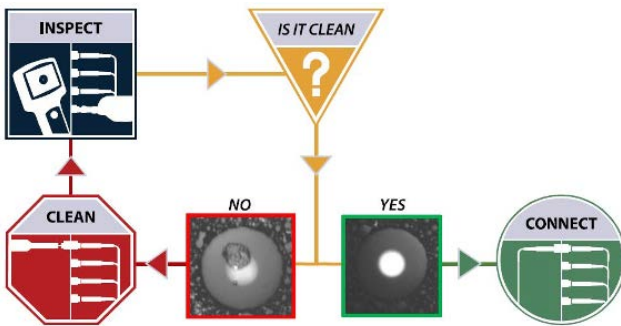

All fibre connector end faces, including those of the Test Reference Cords (TRCs) and bulkhead adapters, should be inspected prior to testing to ensure that they are free from damage or contamination

- damaged fibre end faces should be re-terminated
- dust can be removed using a ‘One Click’ cleaner
- grease or oil (fingerprints) can be removed using a solvent dampened wipe or swab

Ideally the fibre end face should be inspected using a video microscope that can certify to industry standard IEC 61300-3-35 as this provides an automated PASS/FAIL result. The video microscope should also have the ability to save an image of the fibre end face against the link performance test results.



From the above images it can be seen that cleaning once may not be enough and that it is important to re-inspect the fibre end face after each cleaning operation.

Examples of video inspection microscopes:

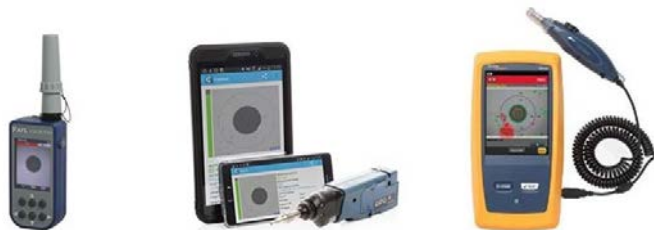

5.2 Fibre Test Equipment

There are two categories of fibre testing, Tier 1 and Tier 2. Tier 1 testing is suitable for certifying the performance of the fibre cabling and Tier 2 testing can be used to compliment this. However, Tier 2 testing is not generally considered suitable for certifying multimode fibre cabling by itself; it would usually be used in conjunction with Tier 1 testing.

5.2.1 Tier 1 Fibre Test Equipment

The purpose of Tier 1 testing is to measure the length and attenuation (loss) of a fibre link, check polarity of the connectors and document the results. Tier 1 testing can be carried out using either an Optical Loss

Optical Loss Test Set (OLTS)

An OLTS provides testing of two fibres in a duplex link in both directions and at two different wavelengths. It analyses the test results against a standards database and provides a simple PASS/FAIL result. An OLTS may be a dedicated device or a special 'module' that attaches to a copper cabling tester.



Light Source & Power Meter (LSPM)

A light source and a power meter are two different devices that, when used as a pair, enable the attenuation (loss) of a link to be calculated. These devices test a single fibre at a single wavelength at a time but they are not generally able to determine the length of the fibre. They are also not able to provide a simple PASS/FAIL result. Instead, the measured attenuation must be compared to a calculated loss budget for the link under test.



Typical Light Sources and Power Meters

5.2.2 Calculating a Link Loss Budget

Use the following equation to calculate the maximum link loss:

Loss Budget (dB) = Cable Attenuation + Connector Attenuation + Splice Attenuation, where :

Cable Attenuation = Attenuation Coefficient (see table below) x Length

Connector Attenuation = No. of Mated Pairs x Connector Loss

Apply 0.75 dB loss per mated connector pair

Splice Attenuation = No. of Splices x Splice Loss

Apply 0.3 dB loss per splice

WAVELENGTH(S)	MULTIMODE		SINGLEMODE	SINGLEMODE INSIDE PLANT	SINGLEMODE OUTSIDE PLANT
	850nm	1300nm	Int/Ext	Singlemode	1310nm & 1550nm
ATTENUATION	3.5	1.5	Inside Plant	Singlemode	0.5

As per ANSI/TIA-568-C

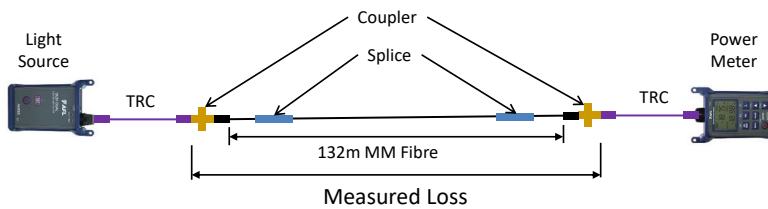

Tested wavelength = 850nm

Loss Budget (dB) = Cable Attenuation + Connector Attenuation + Splice Attenuation

Loss Budget = $(3.5 \times 0.132) + (2 \times 0.75) + (2 \times 0.3) = 2.56\text{dB}$

If the reading at the Power Meter is less than 2.56dB then the Link Under Test has Passed.

5.2.3 Tier 2 Fibre Test Equipment

These are Optical Time Domain Reflectometers (OTDRs) and are not usually used for 'short' LAN fibre links, although they can be useful for locating faults. They require the use of special launch and tail leads to overcome OTDR dead zone limitations in order to measure the loss and reflectance of the first and last connector in the link. If loop back leads are not available then testing from both ends of the link is required.

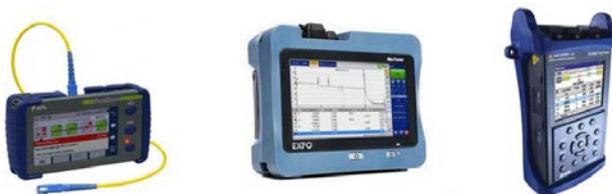

Tier 2 test equipment tends to be more expensive than Tier 1 test equipment and has previously required a more skilled operator, although modern OTDRs do have sophisticated event analysis software to guide users. OTDRs tend to take longer to carry out the testing than an OLTS.

5.3 Encircled Flux (EF)

The use of Encircled Flux launch conditions has been specified in the cabling standards for some time now. It is no longer acceptable to use a mandrel wrap as these provide inaccurate test results and inconsistent results between different pieces of test equipment. The amount of light that enters a fibre, referred to as the launch conditions, directly impacts the accuracy of the link loss measurement. The light source's launch condition determines how and where the light is distributed within the fibre.

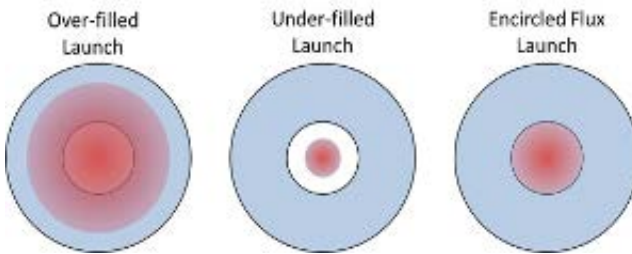

An **overfilled launch** puts too much power in the cladding and higher order modes.

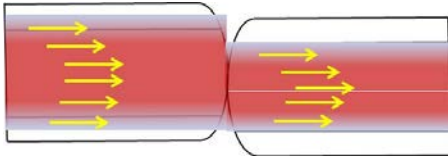

This power gets removed at the first connection and the result is a high or overstated loss value.

An **under-filled launch** puts too little power in the higher order modes

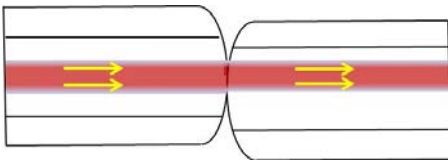

This power does not get removed at the connections and the result is a low or understated loss value.

An **Encircled Flux launch** puts the right amount of light into the higher order modes.

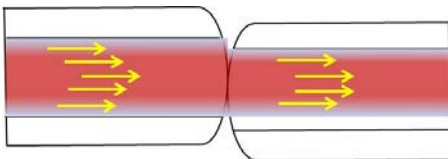

This gives accurate and repeatable measurements of loss.

Modern test equipment is supplied with encircled flux compliant launch conditions but legacy test equipment requires the use of special launch adaptors or leads.

5.4 Test Reference Cords (TRCs)

When testing fibre optic cabling Test Reference Cords (TRCs) should always be used as they are manufactured using high performance connectors with optimal optical Numerical Aperture (NA) and core/ferrule concentricity characteristics.

When mated with other TRCs they produce near zero loss and reduce test result uncertainty. TRCs are called for in various standards for loss measurements of installed fibre cabling. TRCs have typical attenuation losses between two reference connectors of $\leq 0.1\text{dB}$ for multimode and $\leq 0.2\text{dB}$ for singlemode.

Standard fibre optic patch leads should not be used for testing purposes.

5.5 Test Referencing

Before commencing testing it is essential that the test reference cords are referenced out. This should be done at least once per day. Before commencing referencing switch on the test equipment and allow it to warm up for at least 5 minutes; then select and configure the appropriate test limits. Inspect the end faces of the test reference cords and clean if necessary before attaching them to the test equipment. Reference the test cords using the one jumper method (see below). Inspect the end faces of the TRCs and the link under test before attaching the TRCs and carrying out the test.

5.5.1 One Jumper Reference Technique

1. Connect the light source to the power meter using a Test Reference Cord (TRC)
2. Reference the power meter (set to 0dB)
3. Disconnect the TRC from the power meter and connect a second TRC to the power meter port. Do not disconnect the TRC from the Light Source port
4. Verify the reference by connecting the two TRCs together using a precision bulkhead adaptor
5. Measure the loss to ensure good quality TRCs ($\leq 0.1\text{dB}$ for MM, $\leq 0.2\text{dB}$ for SM) and save the test result

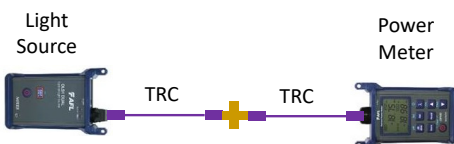
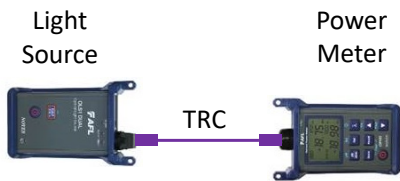

6. Disconnect the TRCs from the bulkhead adaptor and connect to the link under test to measure the loss

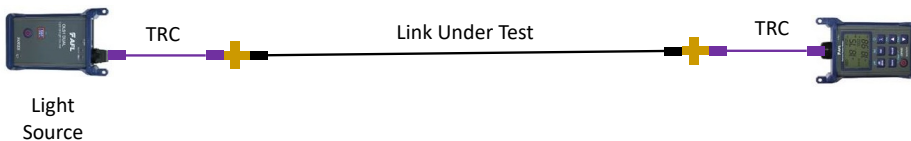

The One Jumper Method calculates the link loss as the loss of the two adaptors and the link under test. It is the preferred method for qualifying the link under test as outlined in ANSI/TIA-568-C. The power meter TRC must have the same connector type as the Link Under Test.

Referencing in this way has been proven to provide the most accurate and repeatable test results.

6.0 HANDOVER DOCUMENTATION

An Operations & Maintenance (O&M) Manual is the document that should be passed to the client on completion of the installation. The O&M Manual should contain, as a minimum:

- 'As Built' drawings
- Details of the cabling system installed
- Test results
- Installer details
- Warranty documentation
- Routine maintenance requirements

6.1 'As Built' Drawings

The 'As Built' drawings should be supplied in a printed format and should show:

- Key cable routes
- Location and numbering of work area outlets
- Location of Comms Room
- Location of distribution cabinets & frames
- Location of grounding and earthing points
- Details of labelling scheme used
- Building entry points for external services

6.2 Solution Installed

Full details of the installed cabling solution should be provided. These should include the name and contact details for the cabling system manufacturer, a full bill of materials (BOM) and copies of the relevant manufacturer's product datasheets.

6.3 Test Results

A summary test report should be provided showing the port/link identification, the test results, the test standard used, the length of the tested link, the margin of performance and the date and time that the test was carried out. The full test reports should be provided in electronic format, either as a PDF document or in the tester manufacturer's format. The installer should also provide details of the test equipment used, copies of the tester calibration certificate(s) and details of the test methodology that was used.

6.4 Installer Details

Full contact details for the installer that carried out the cabling installation should be provided in the O&M Manual, together with a copy of their manufacturer accreditation certificate for the cabling solution installed. This will provide the client with the appropriate contact information should there be a problem with the cabling installation at some point in the future or if the client should require any additional work to be carried out.



6.5 Warranty

A copy of the cabling system manufacturer's warranty certificate should be provided, together with the warranty terms and conditions. The client should be made aware of any conditions placed upon them to maintain the validity of the warranty. This may include, but not be restricted to, using only patch leads from the cabling system manufacturer.

6.6 Routine Maintenance

Details of any routine maintenance that should be carried out should be provided, including relevant cleaning methods and materials.

7.0 TERMINATION INSTRUCTIONS

7.1 Rear Punch UTP Patch Panels



776503 (Cat5e 24 Port)
776504 (Cat5e 48 Port)
779333 (Cat6 24 Port)
795077 (Cat6 48 Port)



782682 (Cat5e)
789242 (Cat6)
791330 (Cat6+)

1. Remove approximately 50mm of the cable sheath and separate the 4 pairs. For Cat6 cables carefully cut back the central plastic separator flush with the cable sheath
2. Where fitted remove the rear cable management bar by gently pulling the 'wings' outwards

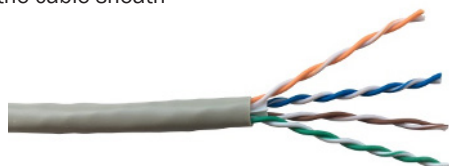

3. Dress the wires in to the appropriate coloured IDC slots following the preferred wiring configuration. Ensure that the cable pair twists are maintained as close as possible to the point of termination
4. Punchdown the wires using a Krone type or 110 style termination tool

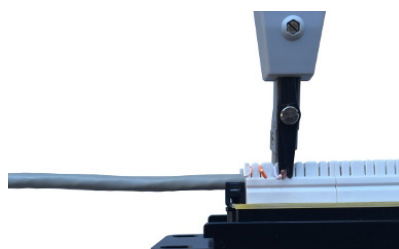
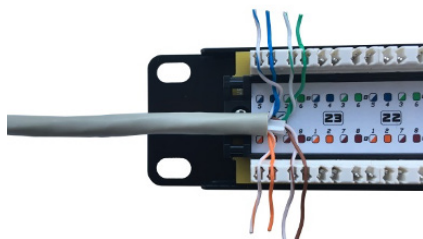

5. When all of the cables have been terminated re-fit the cable management bar (where provided)

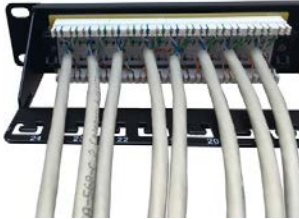

6. Secure the cables to the cable management bar using cable ties, taking care not to over tighten them



Note: For Cat5e patch panels where a rear cable management bar is not provided the terminated cables should be dressed to either side of the patch panel using the cable management rings and cable tie points provided.



Recommended Tools:

PART NUMBER	DESCRIPTION	PURPOSE
994080	Side Cutters - 160mm	Cutting cable to length
993874	Cyclops Sheath Cutter	Cutting sheath
770218	Inserter Wire 110	Terminating and trimming wires
773118	Inserter Wire 2A	Terminating and trimming wires

7.2 Patch Panels UTP Right Angle



771833 (Cat5e 24 Port)
783005 (Cat6 24 Port)



777649 (Cat5e 48 Port)
789963 (Cat6 48 Port)

1. Remove approximately 50mm of the cable sheath and separate the 4 pairs. For Cat 6 cables carefully cut back the central plastic separator flush with the cable sheath

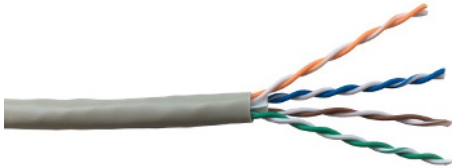

2. Place the cable so that the sheath end is close to the rear end of the IDC block



3. Dress the wires in to the appropriate coloured IDC slots following the preferred wiring configuration. Ensure that the cable pair twists are maintained as close as possible to the point of termination

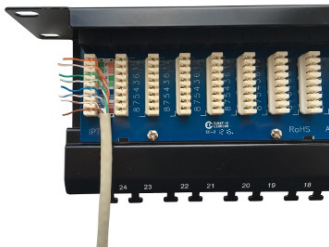

4. Punchdown the wires using a Krone type termination tool

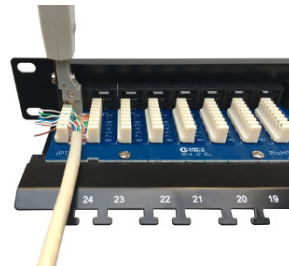

5. Secure the terminated cable to the cable management tray using a cable tie, taking care not to over tighten it



Recommended Tools:

PART NUMBER	DESCRIPTION	PURPOSE
994080	Side Cutters - 160mm	Cutting cable to length
993874	Cyclops Sheath Cutter	Cutting sheath
809585	Electronic Flush Cutters	Cutting back cable central separator
773118	Inserter Wire 2A	Terminating and trimming wires

7.3 Low Profile Modules



771836 (Cat5e Euro White)
787117 (Cat5e Euro Black)
779332 (Cat6 Euro White)
789835 (Cat6 Euro Black)



772412 (Cat5e LJ6C White)
779331 (Cat6 LJ6C White)
789845 (Cat6 LJ6C Black)



796053 (Cat6 Euro White)

1. Remove approximately 50mm of the cable sheath and separate the 4 pairs. For Cat6 cables carefully cut back the central plastic separator flush with the cable sheath
2. After deciding if cable entry will be at the top or bottom of the module place the cable so that the sheath end is close to the nearest IDC slots

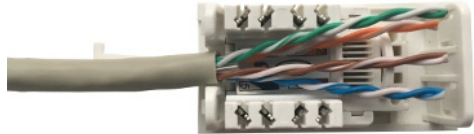
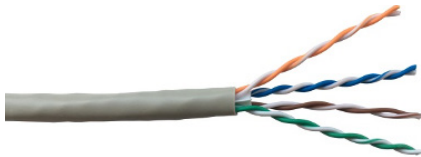

3. Dress the wires in to the appropriate coloured IDC slots following the preferred wiring configuration. Ensure that the cable pair twists are maintained as close as possible to the point of termination
4. Punchdown the wires using a Krone type or 110 style termination tool

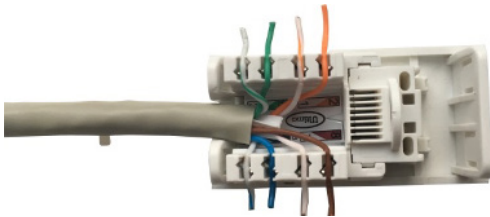

5. When all of the wires have been terminated secure the cable to the strain relief tag or loop using a cable tie, taking care not to over tighten it
6. Fit the wire retention cap



Recommended Tools:

PART NUMBER	DESCRIPTION	PURPOSE
994080	Side Cutters - 160mm	Cutting cable to length
993874	Cyclops Sheath Cutter	Cutting sheath
809585	Electronic Flush Cutters	Trimming cable tie
770218	Inserter Wire 110	Terminating and trimming wires
773118	Inserter Wire 2A	Terminating and trimming wires

7.4 Standard Modules



778649 (Cat5e)

791329 (Cat6)

1. Remove approximately 50mm of the cable sheath and separate the 4 pairs. For Cat6 cables carefully cut back the central plastic separator flush with the cable sheath
2. Place the cable so that the sheath end is close to the centre of the IDC contacts

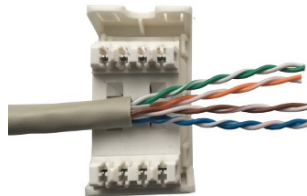
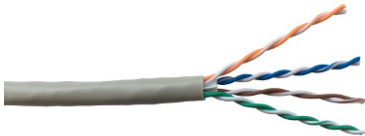

3. Dress the wires in to the appropriate coloured IDC slots. Ensure that the cable pair twists are maintained as close as possible to the point of termination

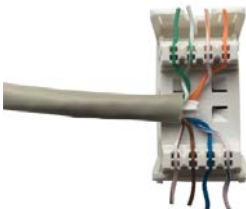

4. Punchdown the wires using a Krone type or 110 style termination tool



5. When all of the wires have been terminated secure the cable to the strain relief slots using a cable tie, taking care not to over tighten it

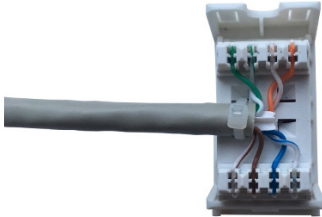

Recommended Tools:

PART NUMBER	DESCRIPTION	PURPOSE
994080	Side Cutters - 160mm	Cutting cable to length
993874	Cyclops Sheath Cutter	Cutting sheath
770218	Inserter Wire 110	Terminating and trimming wires
773118	Inserter Wire 2A	Terminating and trimming wires

7.5 Keystone Jacks 90 Degree Punchdown



789768 (Cat5e White)

789769 (Cat6 White)

792379 (Cat6 Black)

1. Remove approximately 50mm of the cable sheath and separate the 4 pairs. For Cat6 cables carefully cut back the central plastic separator flush with the cable sheath

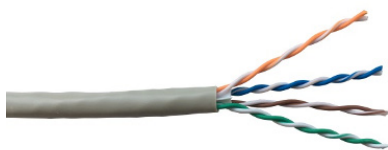

2. To assist termination it is recommended that the keystone jack is mounted in section 'B' of the keystone termination puck (puck supplied free of charge with a box of 25 keystone jacks)

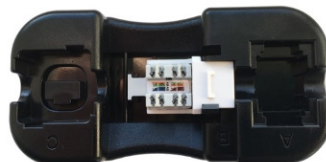

3. Present the cable at the rear of the jack and dress the wires in to the appropriate coloured IDC slots following the preferred wiring configuration

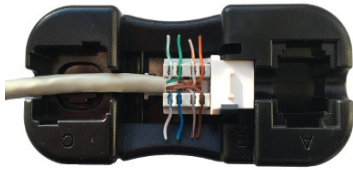

4. Punchdown the wires using a 110 style termination tool



5. Remove the jack from the keystone puck and fit the wire retention cap

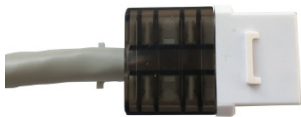

6. Secure the cable to the strain relief flange using a cable tie, taking care not to over tighten it



Recommended Tools:

PART NUMBER	DESCRIPTION	PURPOSE
994080	Side Cutters - 160mm	Cutting cable to length
993874	Cyclops Sheath Cutter	Cutting sheath
809585	Electronic Flush Cutters	Trimming cable tie
770218	Insurer Wire 110	Terminating and trimming wires

7.6 Keystone Jacks 90 Degree Toolless



790013 (Cat5e White)

790014 (Cat6 White)

792380 (Cat6 Black)

1. Remove approximately 50mm of the cable sheath and separate the 4 pairs. For Cat6 cables carefully cut back the central plastic separator flush with the cable sheath



2. Dress the wires in to the appropriate coloured slots on the jack following the preferred wiring configuration

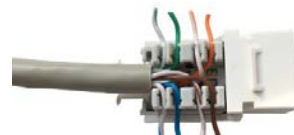

3. Cut the wires flush with the outside edge of the jack termination blocks



4. Fit the wire termination cap over the wires and press down to seat wires

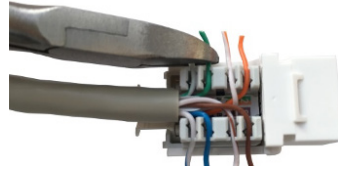

5. Locate the top cover in to the curved slots on the keystone jack body

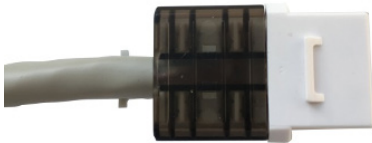

6. Close the rear cover of the jack



7. It should lock closed with an audible 'click'



8. Secure the cable to the anchor point on the rear of the jack using the cable tie supplied taking care not to over tighten



Recommended Tools:

PART NUMBER	DESCRIPTION	PURPOSE
994080	Side Cutters - 160mm	Cutting cable to length
993874	Cyclops Sheath Cutter	Cutting sheath
809585	Electronic Flush Cutters	Trimming cable tie

7.7 Keystone Jacks 180 Degree Punchdown



781934 (Cat5e White)

781935 (Cat6 White)

792381 (Cat6 Black)

1. Remove approximately 50mm of the cable sheath and separate the 4 pairs. For Cat6 cables carefully cut back the central plastic separator flush with the cable sheath

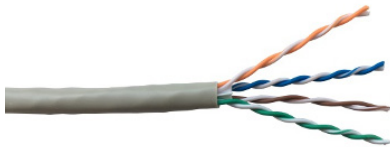

2. To assist termination it is recommended that the Keystone jack is mounted in section 'A' of the keystone termination puck (puck supplied free of charge with a box of 25 keystone jacks)



3. Present the cable at 90° to the rear of the jack and dress the wires in to the appropriate coloured IDC slots following the preferred wiring configuration



4. Punchdown the wires using a 110 style termination tool



5. Remove the jack from the keystone puck. Rotate the cable through 90° so that it is perpendicular to the jack

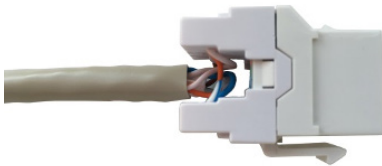

5. Fit the wire retention cap

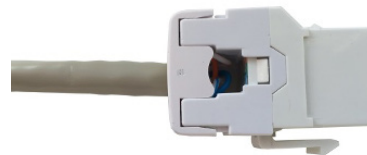

Recommended Tools:

PART NUMBER	DESCRIPTION	PURPOSE
994080	Side Cutters - 160mm	Cutting cable to length
993874	Cyclops Sheath Cutter	Cutting sheath
809585	Electronic Flush Cutters	Trimming cable tie
770218	Inserter Wire 110	Terminating and trimming wires

7.8 Keystone Jacks 180 Degree Toolless



789771 (Cat5e White)
789772 (Cat6 White)
793782 (Cat6 Black)

1. Remove approximately 50mm of the cable sheath and separate the 4 pairs. For Cat6 cables carefully cut back the central plastic separator flush with the cable sheath

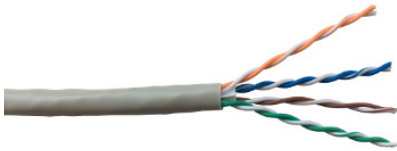

2. Pass the wires through the hole in the rear of the wire retention cap



3. Dress the wires in to the appropriate coloured slots following the preferred wiring configuration

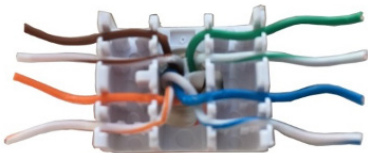

4. Cut the wires flush with the outside edge of the wire retention cap



5. Fit the wire retention cap to the rear of the jack (it will only fit one way round) and push it down to seat the wires in to the IDC slots



6. Close the rear covers of the jack



5. They should lock closed with an audible 'click'

6. Secure the cable to the anchor point on the rear of the jack using the cable tie supplied taking care not to over tighten



Recommended Tools:

PART NUMBER	DESCRIPTION	PURPOSE
994080	Side Cutters - 160mm	Cutting cable to length
993874	Cyclops Sheath Cutter	Cutting sheath
809585	Electronic Flush Cutters	Trimming cable tie

7.9 Keystone Cat6A Toolless Jack



816144

1. Remove approximately 50mm of the cable sheath, cut back the rip cord and separate the 4 pairs

2. Fold the foil of one of the pairs back and wrap it around the outside of the cable sheath with the silver surface on the outside. Wrap the drain wire around the outside of the foil and sheath.



3. Remove the foils from all of the remaining pairs of wires, taking care to cut them back as close as possible to the end of the cable sheath



4. Pass the wires through the hole in the rear of the wire retention cap and dress the wires in to the appropriate coloured slots following the preferred wiring configuration

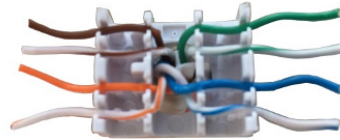

5. Cut the wires flush with the outside edge of the wire retention cap using a pair of flush cutters

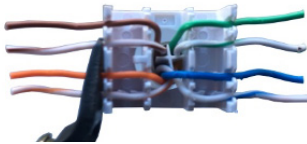

6. Fit the wire retention cap to the rear of the jack (it will only fit one way round) and push it down to seat the wires in to the IDC slots

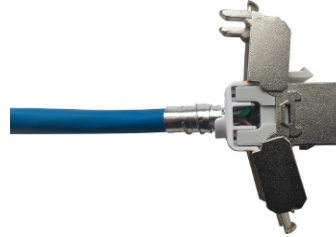

7. Close the rear covers of the jack. You may find the use of Keystone Easy Tool helps. They should lock closed with an audible 'click'



8. Fit the cable tie around the flanges on the rear of the jack and tighten so that the flanges are in contact with the metal foil of the cable. Trim the excess cable tie



Recommended Tools:

Part Number	Description	Purpose
994080	Side Cutters - 160mm	Cutting cable to length
993874	Cyclops Sheath Cutter	Cutting sheath
809585	Electronic Flush Cutters	Cutting foils, trimming wires and cable tie
815146	Keystone Easy Tool 180	Closing of rear covers of jack

7.10 Patch Panel Cat6A Right Angle



798926

1. Remove the patch panel cover and the cable earth clamps

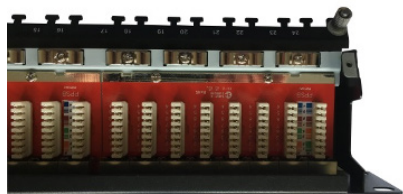

2. Remove approximately 60mm of the cable sheath, cut back the rip cord and separate the 4 pairs

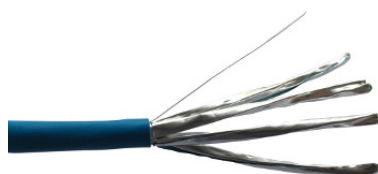

3. Identify the blue pair and carefully open the foil. Fold this foil back along the outside of the cable sheath with the silver surface on the outside. Wrap the drain wire around the outside of the foil and sheath

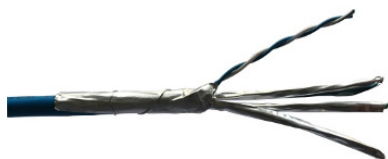

4. Dress the wires in to the appropriate coloured IDC slots following the preferred wiring configuration. For the best performance results ensure that the cable pair foils are maintained as close as possible to the point of termination

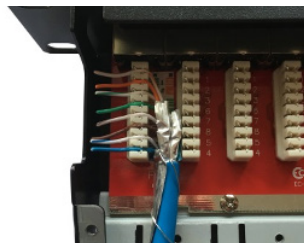

5. Punchdown the wires using a Krone type or 110 style termination tool

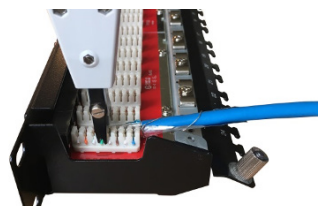

6. When adjacent cables have been terminated fit the shield clamp taking care not to over tighten the screw and crush the cables





5. Secure the cables to the cable management using cable ties, taking care not to over tighten them

6. When all of the cables have been terminated refit the patch panel cover. Make sure that the panel is connected to the cabinet or rack earth using the drain wire provided

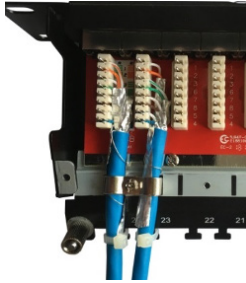

Recommended Tools:

PART NUMBER	DESCRIPTION	PURPOSE
785125	Phillips Screwdriver 80mm	Removal & fitting of cable earth clamps
994080	Side Cutters - 160mm	Cutting cable to length
993874	Cyclops Sheath Cutter	Cutting sheath
809585	Electronic Flush Cutters	Cutting foils and trimming cable ties
773118	Inserter Wire 2A	Terminating and trimming wires
770218	Inserter Wire 110	Terminating and trimming wires



Ultima | T +44 (0)333 443 4430 | E sales@ultima-comms.com | W www.ultima-comms.com

For orders and quotes

Comtec Huntingdon

Cardinal Way
Cardinal Distribution Park
Godmanchester
Huntingdon
PE29 2XJ

T +44(0)1480 415000
E sales@comtecdirect.co.uk

Comtec Glasgow

20 Couper Street
Glasgow
G4 0DL

T +44(0)141 564 1234
E glasgow@comtecdirect.co.uk

Comtec Sunbury

Unit C3, The Dolphin Estate
Windmill Road
Sunbury on Thames
TW16 7HE

T +44(0)1932 331200
E sunbury@comtecdirect.co.uk

Comtec Hong Kong

Unit 1101A, 11/F., Sunbeam Centre
27 Shing Yip Street
Kwun Tong
Kowloon
Hong Kong

T +852 2311 2263
E sales@comtec-comms.com.hk

www.comtecdirect.co.uk