Class E_A shielded solid Patch cords

1. SCOPE

1.1 Content

This specification describes performance and material requirements and tests procedures for AMP NETCONNECT* Class E_A shielded solid patch cord assemblies used to connect building wiring for data and voice networking systems.

1.2 Qualification

When tests are performed on subject product line, procedures specified in Figure 1 shall be used. All inspections shall be performed using applicable inspection plan and product drawing.

2. APPLICABLE DOCUMENTS

The following documents form a part of this specification to the extent specified herein. Unless otherwise specified, the latest edition of the document applies. In the event of conflict between the requirements of this specification and the customer drawing or any Tyco Electronics (TE) documents listed below, the customer drawing and TE documents shall take precedence. In the event of conflict between the requirements of this specification and the industrial standards, this specification shall take precedence.

2.1 Tyco Electronics Documents

A. Relevant customer drawing

B. 230-702: Design for environment standard – ‘Supplier Requirements for the Elimination of Hazardous Substances’

C. 108-93018: Product Specification - ‘Copper LAN cable’

2.2 Industrial Standards:

A. ISO / IEC 11801 2nd Edition: Generic Cabling for Customer Premises

B. Amendment 1 and Amendment 2 to ISO/IEC 11801 2nd Edition.

C. EN 50173-1: Information Technology; Generic Cabling Systems

D. ANSI/TIA/EIA 568-B.2-1: Commercial Building Telecommunications Cabling Standard – Part 2: Balanced Twisted Pair Cabling Components – Addendum 1: Transmission Performance Specifications for 4-Pair 100Ohm Category 6 Cabling

E. ANSI/TIA/EIA 568-B.2-10: Commercial Building Telecommunications Cabling Standard – Part 2: Balanced Twisted Pair Cabling Components – Addendum 10: Transmission Performance Specifications for 4-Pair 100Ohm Augmented Category 6 Cabling

F. IEC 61935-1: Generic cabling systems - Specification for the testing of balanced communication cabling in accordance with ISO/IEC 11801. Part 1: Installed cabling.

G. IEC 61935-2: Specification for the testing of balanced communication cabling in accordance with ISO/IEC 11801. Patch cords and work area cords. Test Specifications as indicated in Fig. 1.

- H. IEC 61156-6: Multicore and symmetrical pair/quad cables for digital communications – Part 6: Symmetrical pair/quad cables with transmission characteristics up to 1000MHz – Work area wiring – Sectional specification.
- I. IEC 60603-7-5: Connectors for electronic equipment. Detail specification for 8-way, shielded, free & fixed connectors, for data transmission with frequencies up to 250 MHz.

3. REQUIREMENTS

3.1 Design and Construction

Product shall be of design, construction and physical dimensions specified on applicable customer drawing.

3.2 Standard length

Applicable standard lengths: *from 1meter to 20meter* (both included).
For other lengths, put in contact with your sales representative.

3.3 Materials

Materials shall be in accordance to Tyco Electronics requirements about environmental-related substances as per Tyco Electronics specification 230-702.
The material of the cable jacket is identified on the customer drawing and shall comply with the standards mentioned in Product Specification 108-93018 *Copper LAN cable*.

3.4 Ratings

Operating Temperature: -20 to 60°C

3.5 Packaging

Each assembly shall be supplied in a clear bag.

3.6 Bending radius

The minimum bending radius is 8x outside diameter during installation and 4x the outside diameter after installation.

3.7 Performance requirements and test procedures

Product is designed to meet electrical, mechanical and environmental performance requirements specified in Figure 1. Depending on sample length only part of the transmission requirements are requested:

- ✓ In case of Class E_A shielded solid **patch cords ≥5meter** **ALL** requirements listed in Figure 1 are applicable.
- ✓ In case of Class E_A shielded solid **patch cords <5meter** **ONLY Class E_A Channel** requirements listed in Figure 1 are applicable.

Unless otherwise specified, all tests shall be performed at ambient environmental conditions.

Test Description	Requirement	Test Procedure
VISUAL		
Examination of product.	Meets requirements of product drawing.	Visual inspection criteria as defined in IEC 61935-2, Paragraph 5.1.
ELECTRICAL		
Wire map	Continuity and short circuit Wire map configuration as per TIA 568B	Any device which ensures quality
Shield continuity	Shield continuity	Any device which ensures quality

TRANSMISSION		
Cat 6 Patch cord requirements [only applicable for PC lengths ≥ 5meter]		
Return Loss ⁽¹⁾	Cat 6 Return Loss cord requirements according to ISO/IEC 11801 2 nd Edition Amend. 2	IEC 61935-2, Paragraph 5.6
NEXT Loss	Cat 6 NEXT Loss cord requirements according to ISO/IEC 11801 2 nd Edition Amend. 2	IEC 61935-2, Paragraph 5.7
Class E_A Channel requirements (See Figure 2 for test set up) [applicable for all PC lengths]		
Return Loss	Class E _A Channel Return Loss requirements according to ISO/IEC 11801 2 nd Edition Amend. 1	IEC 61935-1, Paragraph 4.11
Insertion Loss	Class E _A Channel Insertion Loss requirements according to ISO/IEC 11801 2 nd Edition Amend. 1	IEC 61935-1, Paragraph 4.5
NEXT Loss	Class E _A Channel NEXT requirements according to ISO/IEC 11801 2 nd Edition Amend. 1	IEC 61935-1, Paragraph 4.7
PS NEXT Loss	Class E _A Channel PS NEXT requirements according to ISO/IEC 11801 2 nd Edition Amend. 1	(PS NEXT is computed from NEXT Loss values)
ACR-N	Class E _A Channel ACR-N requirements according to ISO/IEC 11801 2 nd Edition Amend. 1	IEC 61935-1, Paragraph 4.8
PS ACR-N	Class E _A Channel PS ACR-N requirements according to ISO/IEC 11801 2 nd Edition Amend. 1	(PS ACR-N is computed from ACR-N values)
FEXT Loss	(There are no requirements for FEXT Loss)	IEC 61935-1, Paragraph 4.9
ACR-F	Class E _A Channel ACR-F requirements according to ISO/IEC 11801 2 nd Edition Amend. 1	IEC 61935-1, Paragraph 4.10
PS ACR-F	Class E _A Channel PS ACR-F requirements according to ISO/IEC 11801 2 nd Edition Amend. 1	(PS ACR-F is computed from ACR-F values)
Propagation delay	Class E _A Channel Propagation Delay requirements according to ISO/IEC 11801 2 nd Edition Amend. 1	IEC 61935-1, Paragraph 4.6
Delay Skew	Class E _A Channel Delay Skew requirements according to ISO/IEC 11801 2 nd Edition Amend. 1	IEC 61935-1, Paragraph 4.6
MECHANICAL		
Crimping Height	Relevant IEC 60603-7-X standard	Indicator with needle-point probes or equivalent. It shall be measured at the front of the contact.
Tensile Strength	Force applied: 50 N according to the standard. Duration: 5 seconds	IEC 61935-2, Paragraph 6.2. (See figure 3 as information)

NOTE

See Test Sequence in paragraph 4.2 Figure 4

Figure 1: Requirements and test procedures for Class E_A shielded solid patch cords**REMARK⁽¹⁾**Return Loss values below 4MHz are for information only according to AMD2 to ISO 11801 2nd Edition

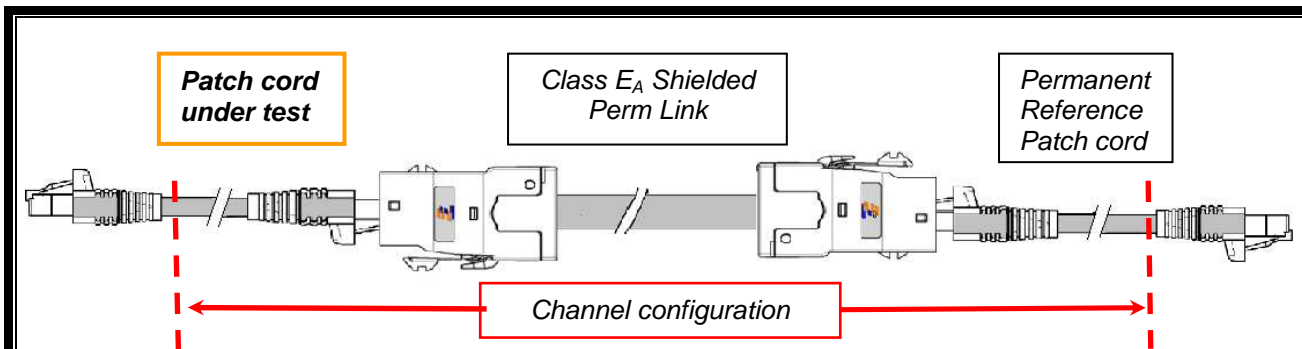

Figure 2: Test set up - Channel configuration

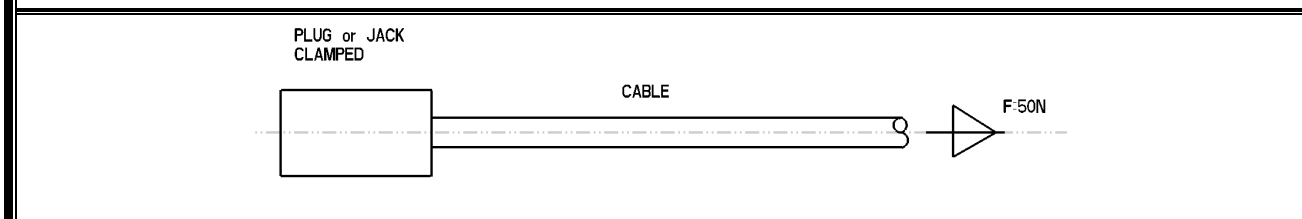
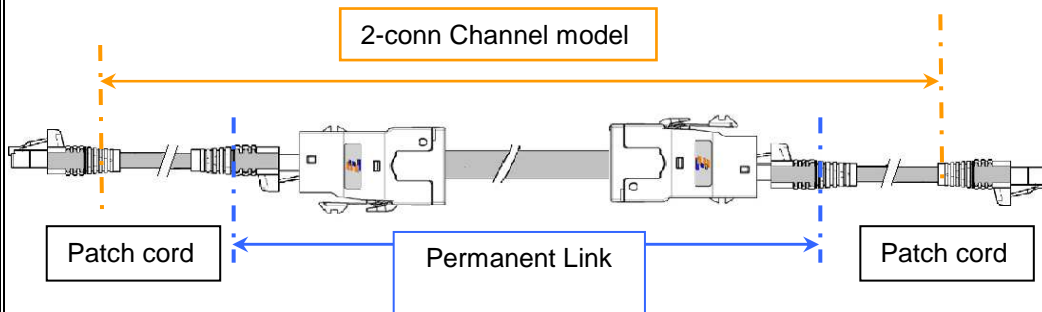

Figure 3: Tensile strength test procedure

In general, patch cords are components of a Channel cabling configuration. Channels are length limited by standards in order to achieve specific requirements, for this reason all component lengths have to be considered for obtaining the expected cabling performance.
 In case of a Class E_A Channel 2-connector model:



NOTE

Maximum patch cords total length allowed is obtained by the following equation:

$$(Max_Length_{Patch_cords} [m] \cdot RatioA) = 104 [m] - (Length_{Permanent_Link} [m] \cdot RatioB)$$

Where RatioA and RatioB are the cable insertion loss ratios which depend on cable type (solid or stranded). In general, they take the following values:

- ✓ For stranded cables, Ratio_{stranded} = 1.5
- ✓ For solid cables, Ratio_{solid} = 1.0

4. PRODUCT QUALIFICATION AND REQUALIFICATION

4.1 Sample Selection

Samples shall be selected at random from current production. For qualification purpose, all test groups shall consist of a minimum of 5 samples per relevant length per product family.

4.2 Test sequence

Class E_A Shielded Solid Patch cord cable assemblies		
Test Description		Test Sequence
Examination of product		1, 18
Wire Map & Shield continuity		3
<i>Patch cord requirements</i> <i>[only applicable for PC lengths ≥5m]</i>	Return Loss	4
	NEXT	5
<i>Channel requirements</i> <i>[applicable for all PC lengths]</i>	Return Loss	6, 19
	Insertion Loss	7, 20
	NEXT	8, 21
	PS NEXT Loss	9, 22
	ACR-N	10, 23
	PS ACR-N	11, 24
	FEXT	12, 25
	ACR-F	13, 26
	PS ACR-F	14, 27
	Propagation Delay	15, 28
	Delay Skew	16, 29
	Crimping Height	2
	Tensile Strength	17

Figure 4: Test sequence

4.3 Requalification Testing

If changes significantly affecting form, fit or function are made to the product or manufacturing process, requalification testing shall be initiated, consisting of all or part of the original testing sequence as determined by Tyco Electronics.

5. QUALITY ASSURANCE PROVISIONS

Quality provisions are based upon the philosophy of TQM (Total Quality Management) with a system approved to EN ISO 9001 by Lloyds Register Quality Assurance.

5.1 Responsibility for quality

Unless otherwise stated in the purchase order, it shall be the supplier's responsibility to assure qualification and lot conformance to this specification. The supplier may utilize his own or other testing and inspection facilities acceptable to the buyer.

5.2 Qualification conformance

For the purposes of internal qualification, the program shall consist of examinations and tests to determine conformance with the requirements of this specification. It shall be performed once, on introduction of the product. Subsequent design changes shall be partially or fully re-qualified depending upon their area of impact in the context of product functionality. Regular requalification testing shall be performed as defined by the Quality Department.

5.3 Manufacturing follow-up

Tyco Electronics products target Six Sigma levels of performance by the integration of capable processes from the development throughout the entire supply chain. The goal is to reduce variability to achieve zero defects for products and services. Systems used are based on preventive and statistical techniques during development and manufacturing. This also includes suppliers of materials, components or systems. Dedicated procedures for supplier selection, development and follow-up are implemented to ensure conformance to TQM and specification requirements.

Best demonstrated practices are identified and implemented throughout the company, with a continuing challenge to identify opportunities for innovation and improvement.