

The optical transceivers are based on 10G Ethernet IEEE 802.3ae standard and SFF-8431 standard, providing a fast and reliable interface for 10G Ethernet applications. The product implements digital diagnostics via a 2-wire serial bus, compliant with the SFF-8472 standard.

Key Features

- Supports from 9.83 Gb/s to 11.3 Gb/s bit rates
- Compliant with IEEE 802.3ae 10GBASE-SR/SW
- Compliant with SFF-8431
- Hot-pluggable SFP+ footprint
- 850nm VCSEL laser transmitter
- Duplex LC connector
- Built-in digital diagnostic functions
- Up to 300m on OM3 MMF
- Low power consumption (Module work consumption <1W)
- Single power supply 3.3V
- RoHS Compliant
- Class 1 laser product complies with EN 60825-1



Applications

- 10GBASE-SR/SW Ethernet
- 10G Fibre Channel
- 10G CPRI

General Specifications

Parameter	Symbol	Min	Typ	Max	Unit	Remarks
Data Rate	DR	9.83	10.3125	11.3	Gb/s	1
Bit Error Rate	BER			10 ⁻¹²		
Operating Temperature	T _C	0		70	°C	3
		-5		85	°C	3
		-40		85	°C	3
Storage Temperature	T _{STO}	-40		85	°C	3
Supply Current	I _{CC}		180	290	mA	4
Input Voltage	V _{CC}	3.14	3.3	3.46	V	
Maximum Voltage	V _{MAX}	-0.5		4	V	4

Notes:

1. IEEE 802.3ae
2. Case temperature
3. Ambient temperature
4. For electrical power interface

Link Distances

Data Rate	Fiber Type	Modal Bandwidth @850nm (MHz-km)	Distance Range (m)
9.83 - 11.3 Gb/s	62.5/125umMMF	160	26
9.83 - 11.3 Gb/s	62.5/125umMMF	200	33
9.83 - 11.3 Gb/s	50/125umMMF	400	66
9.83 - 11.3 Gb/s	50/125umMMF	500	82
9.83 - 11.3 Gb/s	50/125umMMF	2000	300

Optical – Characteristics – Transmitter V_{CC}=3.14V to 3.46V, T_C

Parameter	Symbol	Min	Typ	Max	Unit	Remarks
Output Optical Power	P _{TX}	-7		-1	dBm	1
Optical Center Wavelength	λ _C	840		860	nm	
Optical Modulation Amplitude	OMA		-1.5		dBm	2
Extinction Ratio	ER	3	5.5		dB	
Spectral Width (RMS)	Δλ			0.45	nm	
Relative Intensity Noise	RIN			-128	dB/Hz	
Transmitter Dispersion Penalty	TDP			3.9	dB	
Transmitter Jitter						3
Launch Power of OFF Transmitter	P _{OUT_OFF}			-30	dBm	1

Notes:

- 1.Average
2. IEEE 802.3ae
- 3.According to IEEE 802.3ae requirement

Electrical – Characteristics – Transmitter V_{CC}=3.14V to 3.46V, T_C

Parameter	Symbol	Min	Typ	Max	Unit	Remarks
Input differential impedance	R _{IN}		100		Ω	
Differential data input swing	V _{IN_PP}	180		700	mV	
Transmit disable voltage	V _D	2		V _{CC}	V	
Transmit enable voltage	V _{EN}	V _{EE}		V _{EE} +0.8	V	

Electrical – Characteristics – Receiver $V_{CC}=3.14V$ to $3.46V$, T_c

Parameter	Symbol	Min	Typ	Max	Unit	Remarks
Differential data output swing	V_{OUT_PP}	300		850	mV	
Data output rise/fall time (20%-80%)	t_r/t_f	28			ps	
LOS Assert	V_{LOS_A}	2		V_{CC_HOST}	V	
LOS De-Assert	V_{LOS_D}	V_{EE}		$V_{EE}+0.5$	V	

Digital Diagnostic Functions

The unit supports the 2-wire serial communication protocol as defined in SFF-8472. Digital diagnostic information is accessible over the 2-wire interface at the address 0xA2. Digital diagnostics for the SFP+ are internally calibrated by default. The internal micro control unit accesses the device operating parameters in real time, such as transceiver temperature, laser bias current, transmitted optical power, received optical power and transceiver supply voltage. The module implements the alarm function of the SFF-8472, alerts the user when a particular operating parameter exceeds the factory-set normal range.

DDM Threshold Information

Parameter		Alarm Threshold		Warning Threshold	
		High Value	Low Value	High Value	Low Value
Temperature (°C)	C	90 (5A 00)	-10 (F6 00)	85 (55 00)	-5 (FB 00)
	E	90 (5A 00)	-10 (F6 00)	85 (55 00)	-5 (FB 00)
	I	90 (5A 00)	-45 (D3 00)	85 (55 00)	-40 (D8 00)
Vcc (V)		3.63(8D CC)	2.97 (74 04)	3.46 (87 28)	3.13 (7A 44)
Bias (mA)		15 (1D 4C)	1 (01 F4)	12 (17 70)	2 (03 E8)
TxPower (dBm)		0.79 (2E E0)	-7.97 (06 3C)	0.0 (27 10)	-7.0 (07 CB)
RxPower (dBm)		3.01 (4E 20)	-16.02 (00 FA)	0.0 (27 10)	-13.0 (01 F5)

Block-Diagram-of-Transceiver

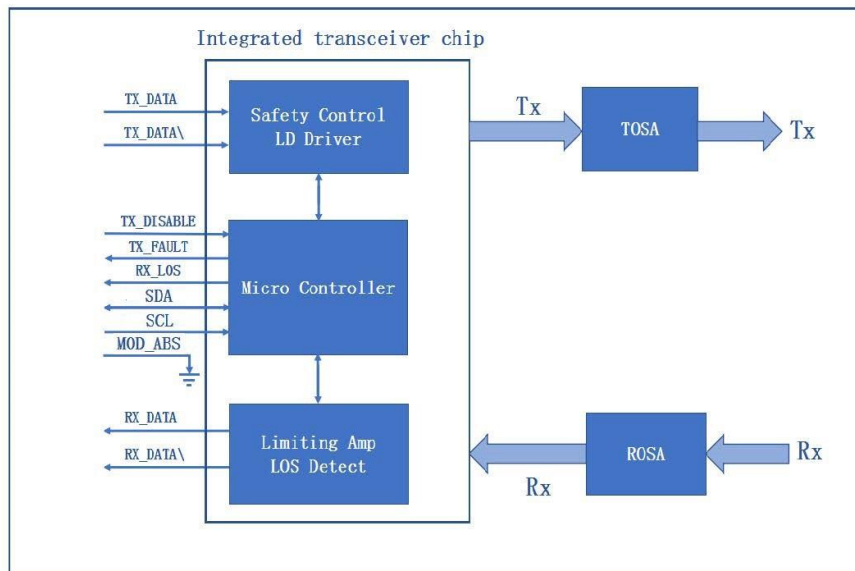

Functions Description

The transmitter is mainly composed of a laser driver part of the intelligent transceiver chip and a TOSA (light-emitting component), the TOSA includes a 850nm VCSEL laser and a backlight photodetection chip, When the module is working, the input signal is connected to the intelligent transceiver chip, at this time, the laser driver of the intelligent transceiver chip supplies the bias current and the modulation current to the laser. The intelligent transceiver chip simultaneously uses an automatic optical power control (APC) feedback loop to maintain a constant average optical power of the laser output. The purpose is to eliminate the change of the output optical signal due to temperature changes and aging of the light source device. When the transmitter enable pin (TX Disable) is high (TTL logic "1"), the laser output is turned off. When TX Disable is low (TTL logic "0"), the laser will turn on within 1ms. When the transmitter fault signal (TX_Fault) is reported as high, indicates a transmitter failure caused by the transmitter's bias current or transmitted optical power or laser tube temperature exceeding a present alarm threshold. Low indicates normal operation.

The receiver is mainly composed of a limiting amplifier part of the intelligent transceiver chip and a ROSA (light-receiving component), the ROSA includes a PIN photodetector and a transimpedance amplifier chip. When the ROSA detects the incident light signal, it will be converted into a photo-generated current by the PIN photodetector. The photo-generated current is converted into an electrical signal after passing through the transimpedance amplifier. The electrical signal is further amplified by the limiting amplifier of

the intelligent transceiver chip, then outputs a fixed-amplitude electrical signal to the host. When the amplitude of the electrical signal received from the incident light conversion of the opposite optical transceiver module is lower than the set threshold, the module reports that the received signal is lost, the RX_LOS pin is high (logic “1”), which can be used to diagnose whether the physical signal is normal. The signal is operated in TTL level. The microprocessor inside the module monitors the module’s operating voltage, temperature, transmitted optical power, received optical power, and laser bias current value in real time. The host acquires this information over a 2-wire serial bus.

After the module is powered on, the read value of the security level access registers 7BH ~ 7EH of A2H is replaced with 0x00. After the content of this group of registers is updated, the read value is the last written value. The security level 1 password of this module is 0x00001011. The method to enter the security level 1 working state is to convert and write the security level 1 password in the A2H 7BH ~ 7EH registers of the module, namely 0x00, 0x00, 0x10, 0x11. After entering the security level 1 working state, the user can directly write to the content of the A0H device address, or modify the content of the A2H 7FH table selection register to write to the contents of Table 00 or Table 01. And this version of the module does not support users to modify the security level 1 password.

Dimensions

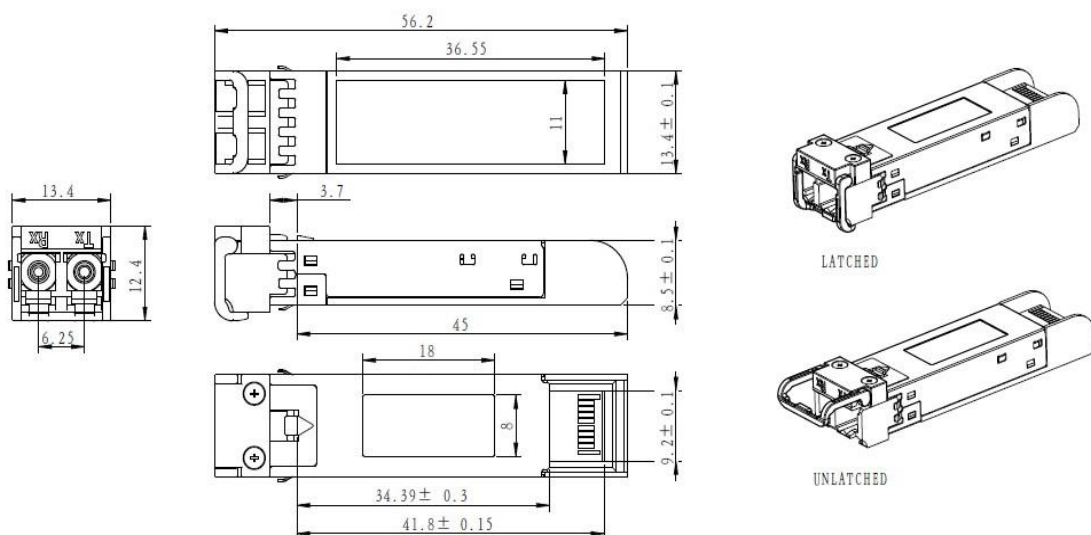

ALL DIMENSIONS ARE ±0.2mm UNLESS OTHERWISE SPECIFIED UNIT: mm

Electrical Pad Layout

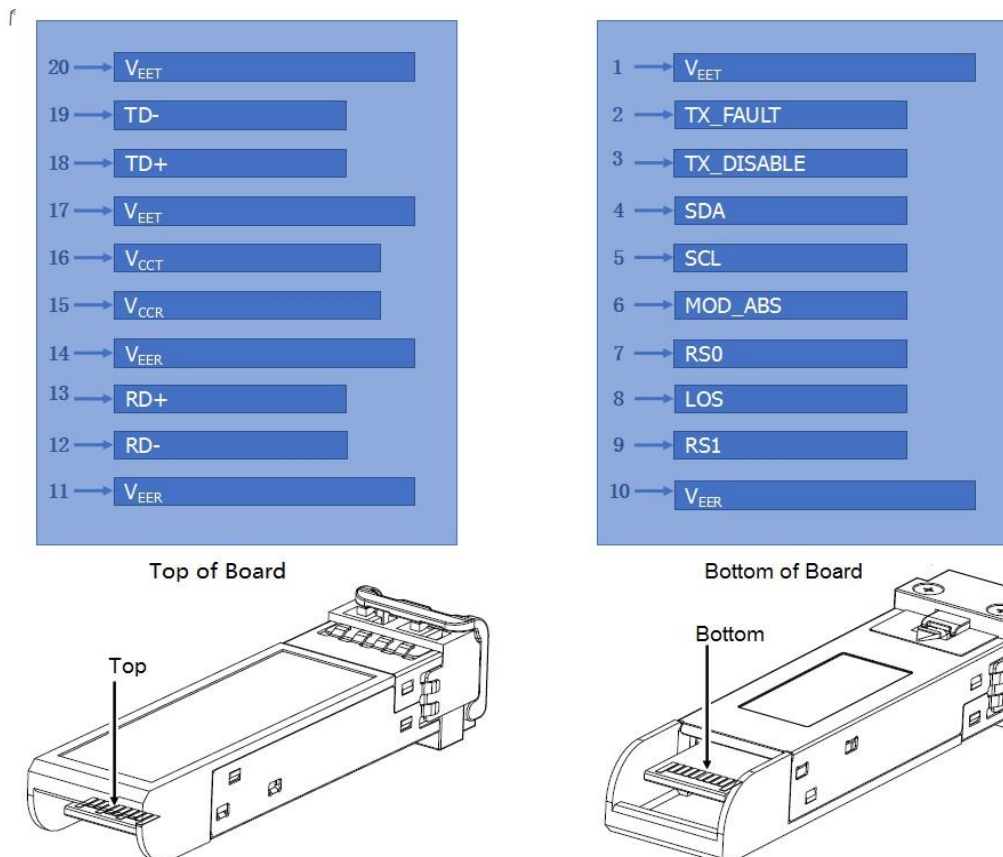

Pin Assignment

PIN #	Symbol	Description	Remarks
1	V _{EET}	Transmitter ground (common with receiver ground)	1
2	TX_FAULT	Transmitter Fault	
3	TX DISABLE	Transmitter Disable. Laser output disabled on high or open	2
4	SDA	2-wire Serial Interface Data Line	3
5	SCL	2-wire Serial Interface Clock Line	3
6	MOD ABS	Module Absent. Grounded within the module	3
7	RS0	No connection required	
8	LOS	Loss of Signal indication. Logic 0 indicates normal operation	4
9	RS1	No connection required	1
10	V _{EER}	Receiver ground (common with transmitter ground)	1
11	V _{EER}	Receiver ground (common with transmitter ground)	1
12	RD-	Receiver Inverted DATA out. AC coupled	
13	RD+	Receiver Non-inverted DATA out. AC coupled	
14	V _{EER}	Receiver ground (common with transmitter ground)	1
15	V _{CCR}	Receiver power supply	
16	V _{CCT}	Transmitter power supply	
17	V _{EET}	Transmitter ground (common with receiver ground)	1
18	TD+	Transmitter Non-Inverted DATA in. AC coupled	
19	TD-	Transmitter Inverted DATA in. AC coupled	
20	V _{EET}	Transmitter ground (common with receiver ground)	1

Notes:

1. Circuit ground is isolated from chassis ground
2. Disabled: T_{DIS}>2V or open, Enabled: T_{DIS}<0.8V
3. Should Be pulled up with 4.7k -10k ohm on host board to a voltage between 2V and 3.6V
4. LOS is open collector output

Ordering Information

Part Number	Description
CHT-SFP-10G-SR	10GBASE-SR SFP+ 850nm LC 300m on MMF, with DOM function, Commercial Temperature (0-70C)

