

## Termination Guide

### Part Number - YPMBP03132

Cat 5e/6 Modular Keystone Panel, 1U/19" 24P UTP Empty,  
For 180° Keystone Jacks, Rear cable management, Black

1. Terminate each 180° keystone jack as per its product termination instructions. Insert each keystone jack into the modular panel keystone ports in sequence. Make sure each jack is securely fixed into the keystone port by its retaining clip.

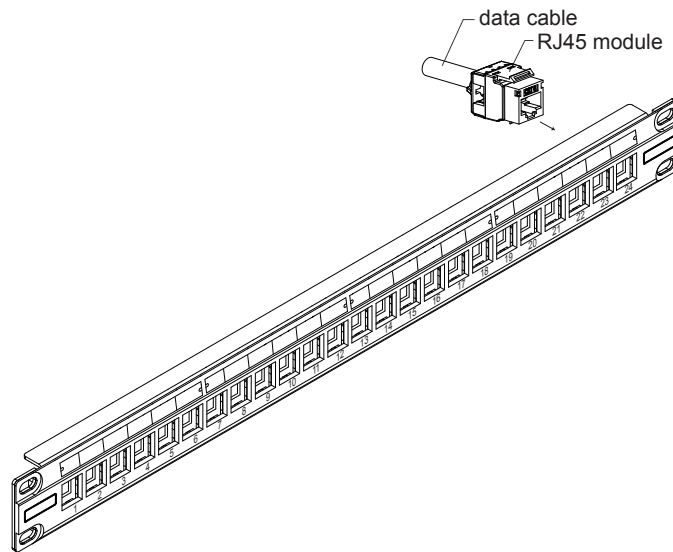

### 2. Bonding/Grounding (Earthed)

If your local code requires this patch panel to be bonded and/or grounded, use the supplied star washer and screw to connect a ground wire (not supplied) for bonding/grounding. The star washer should be placed between the screw head and panel, which must be tightened sufficiently for the star washer to pierce the panel paint and be effective. Connect the bonding/earthing on panel before loading the keystone jacks into the panel at the end with the bonding/grounding screw located.

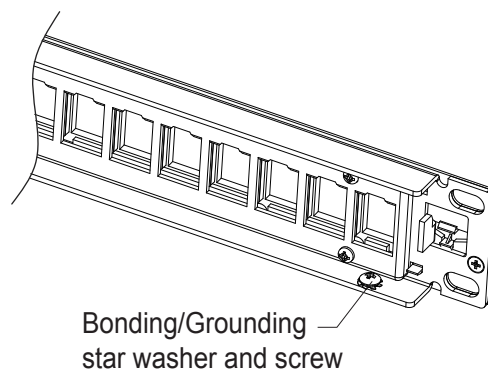

© PRYSMIAN GROUP 2020, All Rights Reserved

All sizes and values without tolerances are reference values. Specifications are for product as supplied by Prysmian: any modification or alteration afterwards of product may give different result.

The information contained within this document must not be copied, reprinted or reproduced in any form, either wholly or in part, without the written consent of Prysmian. The information is believed to be correct at the time of issue. Prysmian reserves the right to amend this specification without prior notice. This specification is not contractually valid unless specifically authorised by Prysmian.

3. Fold out the cable management support bar fixing arms, then slide over the panel fixing points and click down into final fixed position.

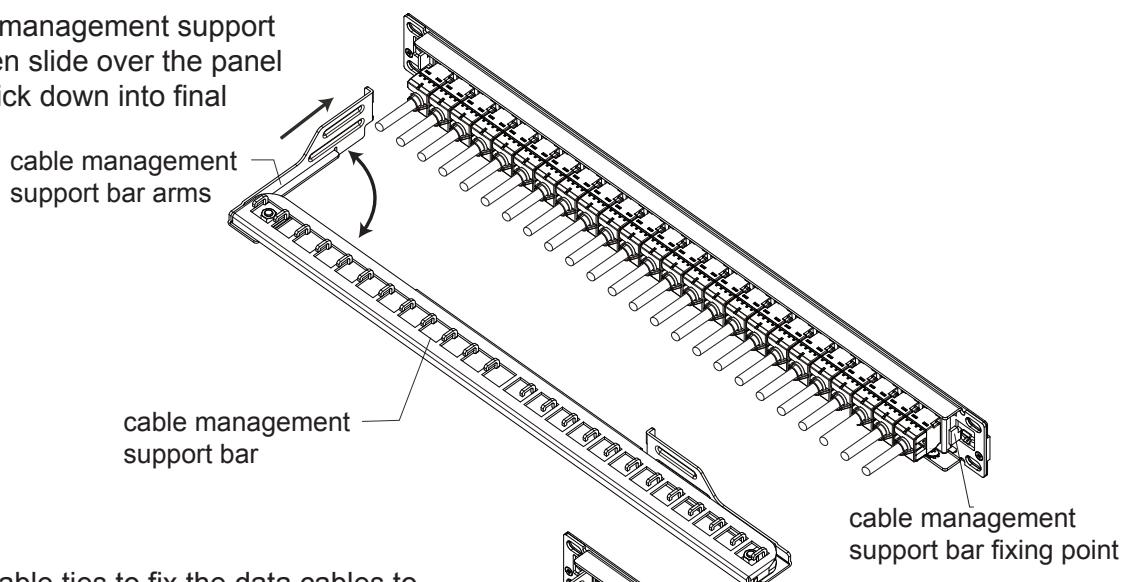

4. Use the supplied cable ties to fix the data cables to the cable support fixing points, located on the cable management support bar. Please take care to not over tighten the nylon cable ties when securing the cable to the panel, as this will stress the cable reducing signal performance.

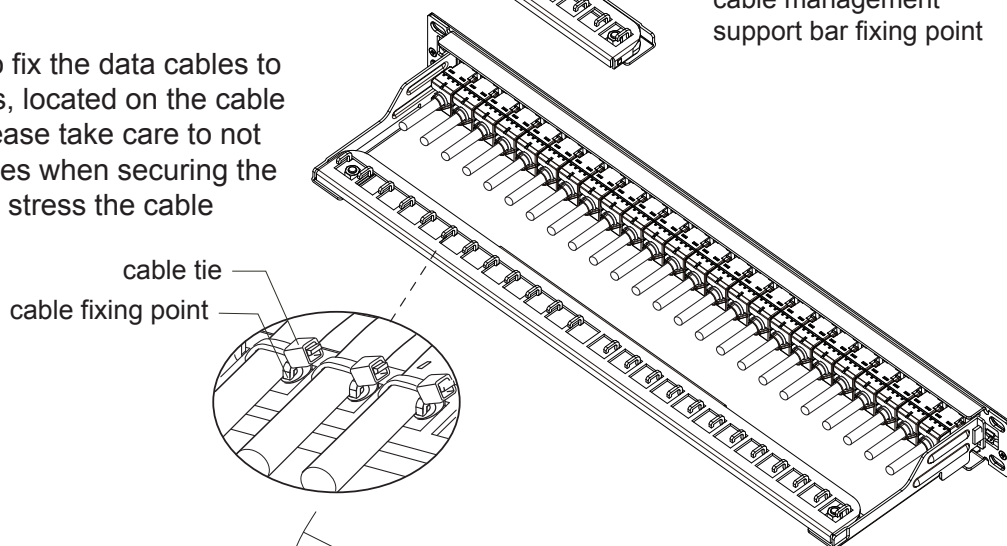

5. Remove plastic cover protecting the port identification labels. Add port descriptions using a permanent marker pen, or by using printed labels. Replace protective cover over labels to complete installation.

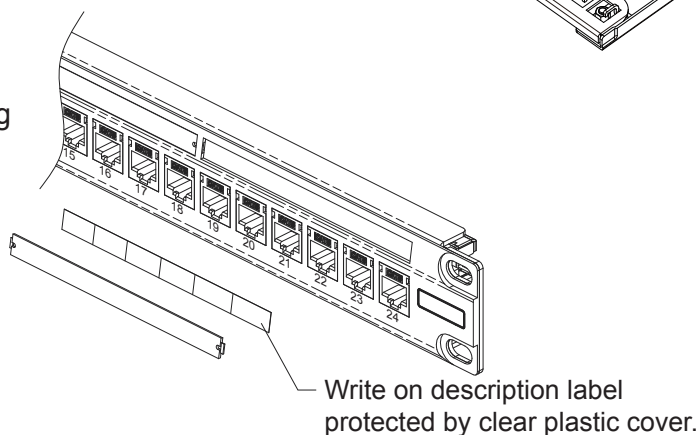

© PRYSMIAN GROUP 2020, All Rights Reserved

All sizes and values without tolerances are reference values. Specifications are for product as supplied by Prysmian: any modification or alteration afterwards of product may give different result.

The information contained within this document must not be copied, reprinted or reproduced in any form, either wholly or in part, without the written consent of Prysmian. The information is believed to be correct at the time of issue. Prysmian reserves the right to amend this specification without prior notice. This specification is not contractually valid unless specifically authorised by Prysmian.