

Termination Guide

Part Number - YPPBP03128 / YPPBP03129 / YPPBP03107

Cat5e/Cat6 UTP Horizontal 90° Patch Panel 1U/19"

24port punch down 110/LSA, Rear cable management, Black

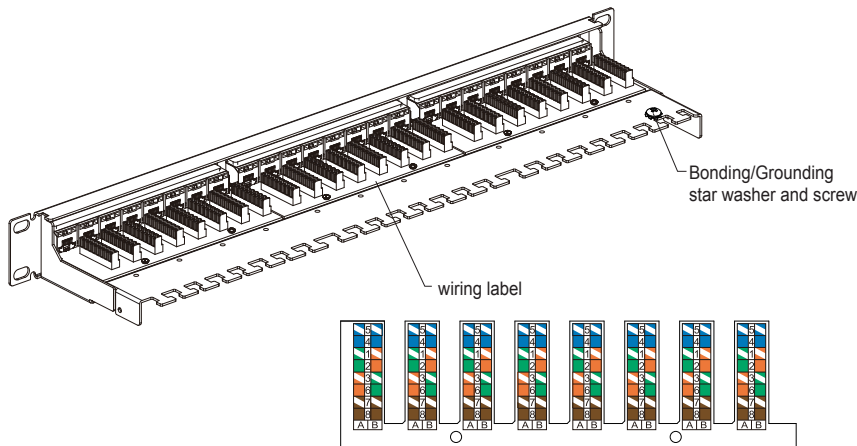

IDC Terminals	T568A Pair/Wire Color	T568B Pair/Wire Color
Pin 5 Pin 4	1 White/Blue Blue	1 White/Blue Blue
Pin 1 Pin 2	2 White/Green Green	2 White/Orange Orange
Pin 3 Pin 6	3 White/Orange Orange	3 White/Green Green
Pin 7 Pin 8	4 White/Brown Brown	4 White/Brown Brown

1. Step 1:

Strip off approx 80mm of the data cable outer jacket, cut out the pair separation spline from the cable if applicable. Follow the TIA 568 A/B color scheme on the panel wiring label, allocating the correct pairs to the 110/LSA IDC slots appropriately. Cable pair twist integrity must remain to the point of termination as much as possible.

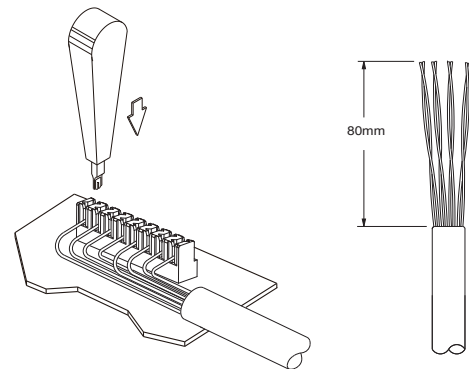

2. Step 2:

Place each pair into the correct IDC slot and punch down each pair using a suitable 110/LSA punch down tool. The termination should be completed in one smooth insertion action, trim off any excess wire if not using an automatic cut off tool. Please continue this process until all terminations are complete.

3. Step 3:

Use the supplied cable ties to fix the data cables to the cable support fixing points, located at rear of panel. Please take care to not over tighten the nylon cable ties when securing the cable to the panel, as this will stress the cable reducing signal performance.

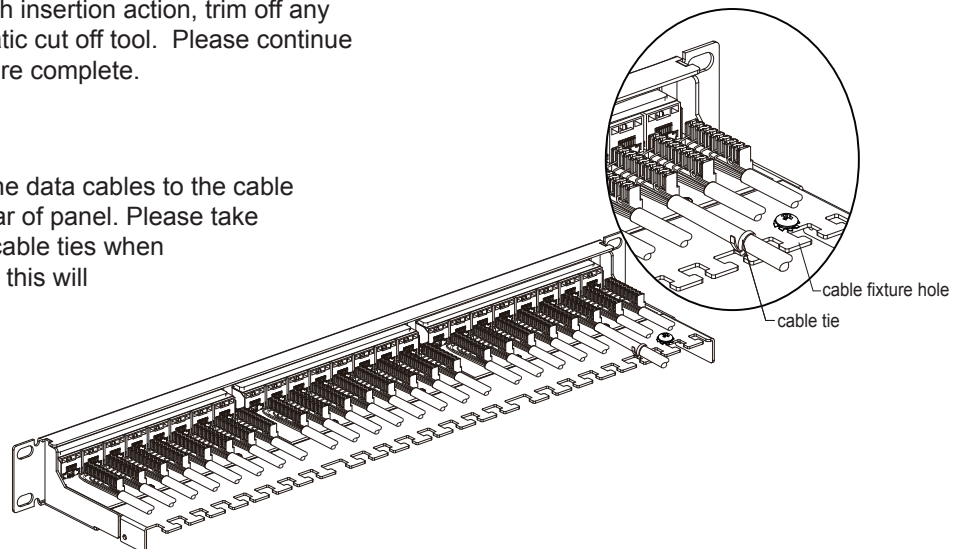

© PRYSMIAN GROUP 2020, All Rights Reserved

All sizes and values without tolerances are reference values. Specifications are for product as supplied by Prysmian: any modification or alteration afterwards of product may give different result.

The information contained within this document must not be copied, reprinted or reproduced in any form, either wholly or in part, without the written consent of Prysmian. The information is believed to be correct at the time of issue. Prysmian reserves the right to amend this specification without prior notice. This specification is not contractually valid unless specifically authorised by Prysmian.

4. Step 4:

Add port descriptions using a permanent marker pen, or by using adhesive printed labels.

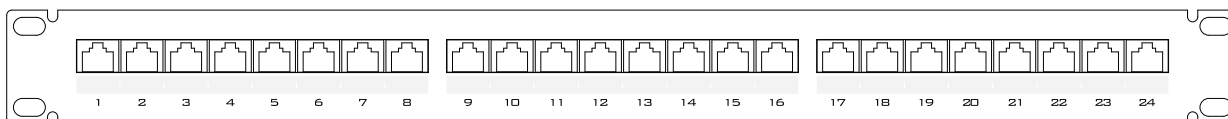

5. Step 5: Bonding/Grounding (Earthed)

If your local code requires this patch panel to be bonded and/or grounded, use the supplied star washer and screw to connect a ground wire (not supplied) for bonding/grounding. The star washer should be placed between the screw head and panel, which must be tightened sufficiently for the star washer to pierce the panel paint and be effective.

© PRYSMIAN GROUP 2020, All Rights Reserved

All sizes and values without tolerances are reference values. Specifications are for product as supplied by Prysmian: any modification or alteration afterwards of product may give different result.

The information contained within this document must not be copied, reprinted or reproduced in any form, either wholly or in part, without the written consent of Prysmian. The information is believed to be correct at the time of issue. Prysmian reserves the right to amend this specification without prior notice. This specification is not contractually valid unless specifically authorised by Prysmian.