

X-Large Flat Screen Wall Mount with Tilt and Swivel

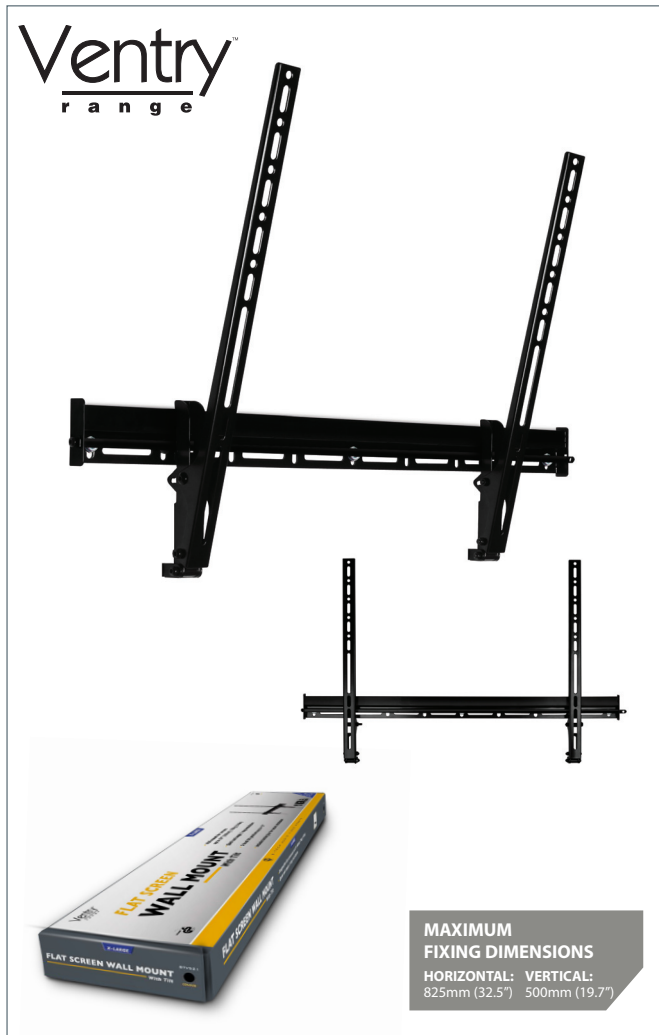

BTV521

Registered Design Number: 001713280-0024



BTV521

X-Large Flat Screen Wall Mount

**Designed for screens up to 63" (160cm)
/ 70kg (154lbs)**

- Fits screens with mounting patterns up to:
H: 825mm (32.5") x V: 500mm (19.7") including
VESA® patterns up to 800 x 500mm
- 5 fixed tilt positions up to +15°
- Mounts screen only 44mm (1.7") from wall
- Includes locking bar for secure installation
- Suitable for concrete, brick or stud walls up to 32"
- Post-installation screen alignment
- Simple hook-on installation with all mounting
hardware included
- Available in Black



Low profile design mounts screen
only 44mm (0.8") from wall



5 fixed tilt positions up to +15°

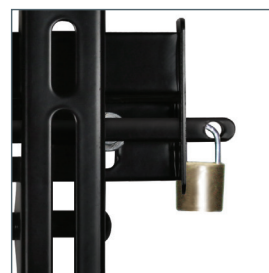

Locking bar for secure installation*



Easy to install in any home

*Padlock not included

SS-BTV521-V1-021111 Page 1 of 2



X-Large Flat Screen Wall Mount with Tilt and Swivel



BTV521

Registered Design Number: 001713280-0024

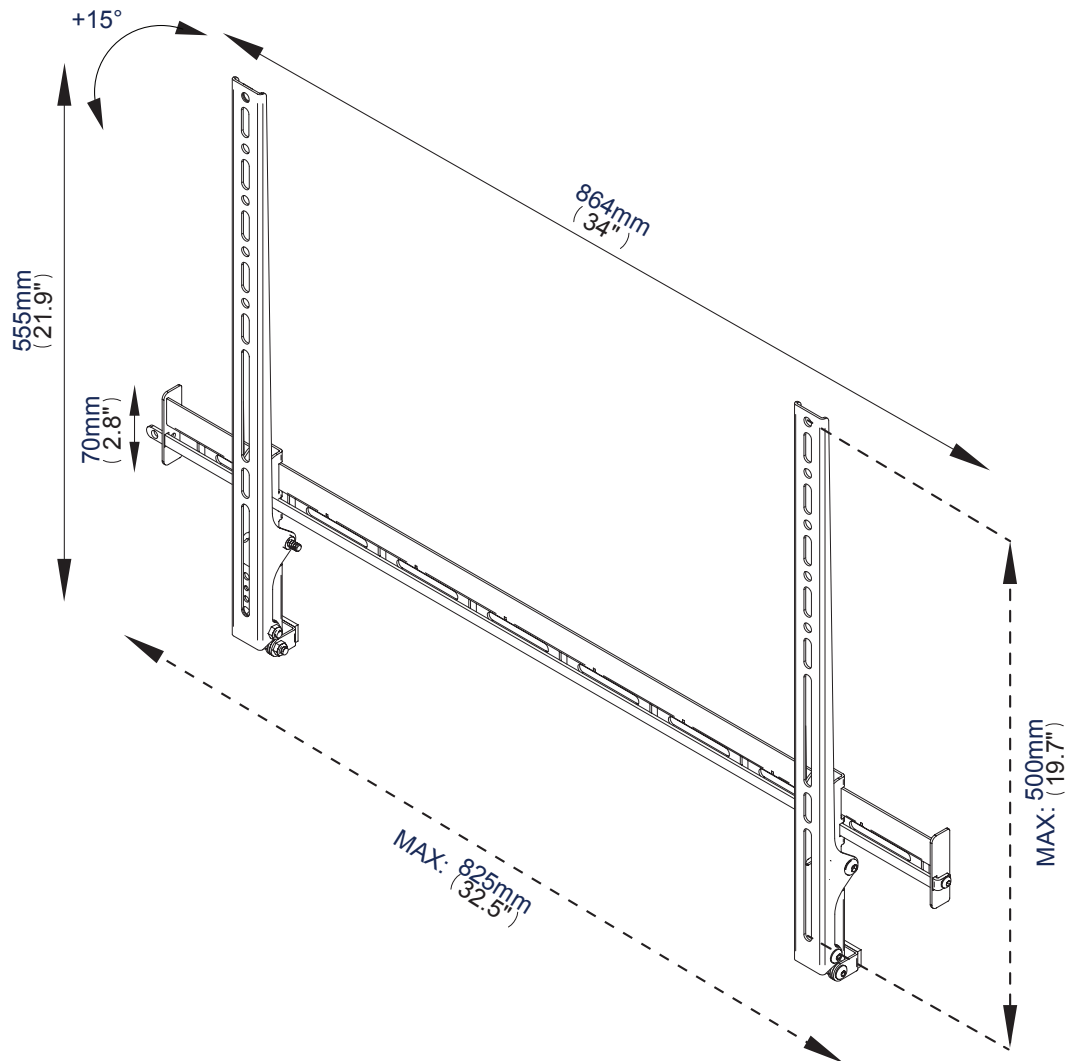

Colour:	Order Ref:	EAN Code:	Master Carton Qty:	Inner Carton Qty:	Master Carton Weight:	Master Carton Cube:
Black	BTV521/B	5019318440113	6	N/A	20.10kg (44.31lbs)	0.034cbm (1.186cuft)

**This information is intended as a guide only and reflects the current specification at the time of print.
B-Tech accepts no liability for the accuracy of the information contained in this document.**